



Rittal – Ri4Power Form 2-4



Type-tested
in accordance
with IEC 60 439-1

Low-voltage systems for electrical distribution
and motor control up to 4000 A

Ri4Power – structured system solutions for the reliable, fast assembly of low-voltage switchgear systems

for machines, plant, and buildings. Rittal Ri4Power is the new name in low-voltage switchgear and distribution enclosures under a single roof – in accordance with the worldwide standard (IEC 60 439-1).

Ri4Power

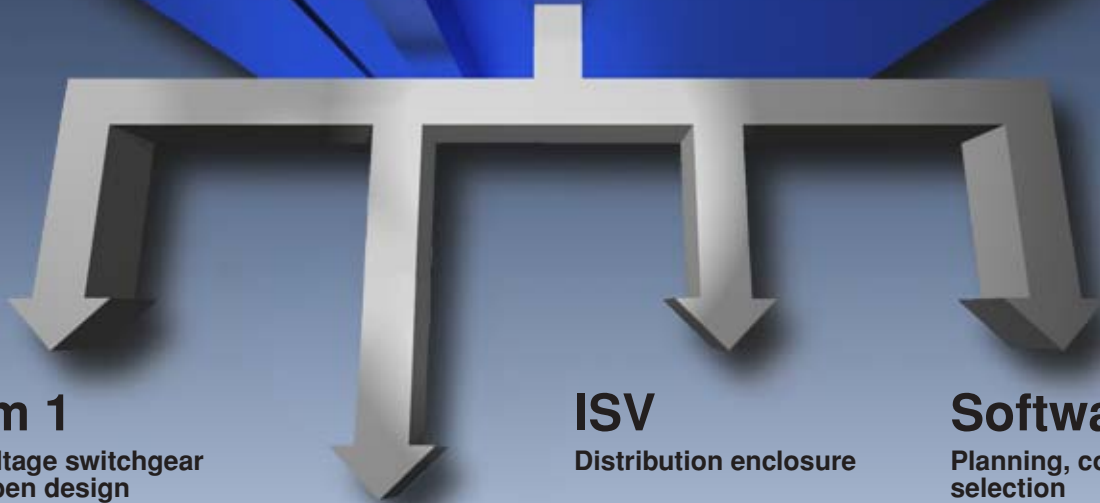

Form 1

Low-voltage switchgear
in an open design

ISV

Distribution enclosure

Software

Planning, configuring,
selection

Form 2-4

Low-voltage switchgear with form separation

Top enclosure system TS 8 in conjunction with busbar systems up to 4000 A as a modular solution.

Applications:

- Process industry
- Water supply/disposal
- Building distribution
- Chemical industry
- Mechanical engineering
- Small power plants
- Wind power

For further information on the Ri4Power system overview,
see page 112/113.



Form 2-4 system examples

from page 9

Complete examples of the principal panel types:

• Power circuit-breaker panel.....	9
• Coupling set panel.....	13
• Outgoing feeder panel.....	17
• Cable management panel.....	21

Form 2-4 enclosures

from page 24

TS 8 Top enclosure system – System platform of infinite possibilities for Ri4Power Form 2-4

• Benefits of the TS 8 system platform.....	25
• SV-TS 8 modular enclosures.....	26
• SV-TS 8 cable chamber enclosures.....	29
• SV-TS 8 busbar enclosures.....	32

Form 2-4 enclosure system accessories

from page 33

The modular system for fast, perfect, individual configuration. Please also refer to Catalogue 32.

• Enclosure configuration (overview).....	33
• Side panels, base/plinths.....	33
• Baying, front trim panels, cross members.....	35
• Partial doors, locks.....	37
• Roof plates, cable entry.....	38

Form 2-4 compartment

from page 40

TS 8-compatible components for simple assembly of compartments

• System benefits, compartment configuration (overview).....	42
• Side panel modules, covers.....	43
• Compartment divider, mounting bracket.....	45
• Partial mounting plates.....	48
• Support frame, punched rails, accessories.....	49

Form 2-4 busbar systems

from page 52

Tested safety, infinite solution diversity, rapid assembly with RiLine60, Maxi-PLS and Flat-PLS

• System benefits of RiLine60.....	53
• RiLine60 bar systems, system components, adaptors.....	55
• System benefits of Maxi-PLS and Flat-PLS.....	73
• Maxi-PLS bar systems, system components, connection components.....	74
• Flat-PLS bar systems, system components, connection components.....	80
• Accessories for RiLine60, Maxi-PLS and Flat-PLS.....	88

Form 2-4 technical information

from page 98

Detailed dimensions, diagrams and other important information for reliable project-planning

• Short-circuit protection diagrams for RiLine60.....	98
• Rated currents of busbars.....	100
• Short-circuit protection diagram for Flexibar "S".....	101
• Maxi-PLS system components, connection components.....	102
• Dimensions of SV-TS 8 enclosures.....	104
• System data.....	107
• Standard transformers.....	111

Ri4Power system overview

from page 112

Forms 2-4: Universal in best form



Process industry

- Sewage treatment plant
- Heavy industry (mining, iron, steel)
- Cement works
- Waste disposal industry
- Paper industry
- Chemicals, petrochemicals
- Pharmaceutical industry

Industrial plants

- Automotive industry
- Mechanical engineering
- Shipbuilding, marine engineering

Energy generation

- Small power plants
- Wind and solar power
- Biomass power plants

Buildings, infrastructure

- Schools
- Banks
- Insurance companies
- Data centres
- Football stadiums
- Hospitals
- Festival halls and exhibition buildings
- Airports



1. Power circuit-breaker panel

- For switchgear from all well-known manufacturers such as Siemens, ABB, Mitsubishi, Moeller, Merlin Gerin
- Use of open and compact power circuit-breakers

See page 9.

2. Coupling set panel

- Combination of a power circuit-breaker panel with a space-saving busbar riser
- Separation into individual busbar sections to boost equipment availability

See page 13.

3. Outgoing feeder panel

- Flexible design of the interior installation
- Fully insulated distribution busbars with extensive connection system

See page 17.

4. Cable management panel

- Available from a field width of 300 mm
- Optional cable entry from above or below
- Flexible installation with Rittal system accessories

See page 21.

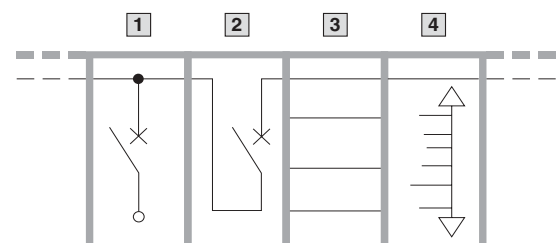

Ri4Power Form 2-4 – An individual system for the configuration of type-tested low-voltage switchgear with inner form separation. The flexible combination of Ri4Power field types supports optimum configuration for your applications.



Forms 2-4: Switchgear with a high level of safety

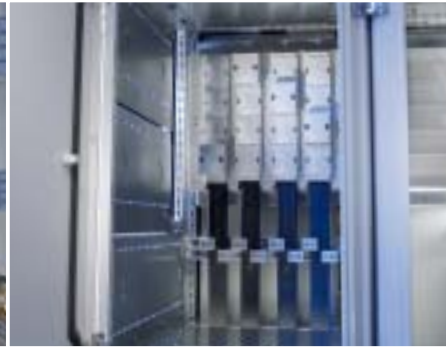

1. Cable connection

- Tested connection system
- Clear arrangement of the cable connection points
- Contacting system with no drilling required
- Space-optimised configuration, even for smaller rated currents

2. Busbar infeed

- An extensive range of accessories to cover the busbar
- Fully insulated busbar connection
- Connection accessories for every type of conductor

3. Side busbar compartment

- Connection accessories for every type of conductor
- Unobstructed access to the busbar compartment from the front
- For the side infeed of compartments



4. Modular outgoing feeder panel

- Safe compartmentalisation
- Logically structured layout of functional units
- Access control, thanks to lockable partial doors
- Combination of control units and power outlet within one enclosure is supported

5. Cable chamber enclosure

- Various options for structured cable routing
- Safe shielding from the compartments
- Solid shielding from the main busbar system

Tested safety

- Type-tested to the internationally valid standard IEC 60 439-1
- Tests with ASTA certification
- Tested accidental arcing protection to IEC 61 641
- Protection category up to IP 54
- Prevention of accidental arcing

Ri4Power Form 2-4 offers the best possible operator protection. Thanks to extensive busbar insulation and sub-division of the compartments, the occurrence and spread of accidental arcs is largely prevented.





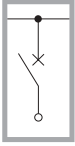

Form 2-4 system example 1

Power circuit-breaker panel



The power circuit-breaker panel is used as the feed to switchgear and the output of large currents from switchgear. Busbar systems up to 4000 A with Maxi-PLS or Flat-PLS **are dimensioned and individually configured according to requirements**. The integrated modular concept and high manufacturing quality ensure **fast, time-saving configuration**. The Ri4Power Form 2-4 system is suitable for power circuit-breakers from all well-known manufacturers such as Siemens, ABB, Mitsubishi, Moeller and Merlin Gerin. Finally, the compartment divider is assembled, ensuring optimum access to all connection points throughout the entire assembly process.

Note:

Use these examples of a power circuit-breaker panel to inspire you. The following information and tools will make project planning easier:

- For diagrams and lists of parts with model numbers for this example, please see page 10/11.
- Software **Rittal Power Engineering** from Version 4.0, see Cat. 32, page 1153.



Example of a comprehensive power circuit-breaker panel design with Ri4Power Form 2-4.

Connection space

- 1** Stepped, assembly-friendly arrangement of the connection bars.
- 2** Cable connection system for optimum connection of all conductor types.
- 3** Flexible positioning of the bars in the connection space thanks to the modular side panel system.

Power circuit-breakers

- 4** Power circuit-breakers available as fixed or rack mounted, allowing a choice of positioning.
- 5** Complete, matching connection systems for ACB power circuit-breakers from all well-known manufacturers (Siemens, ABB, Mitsubishi, Moeller, Merlin Gerin).
- 6** Modular configuration of the compartments, for power circuit-breakers and function groups, in accordance with your requirements.

Busbar system

- 7** Maxi-PLS, alternatively Flat-PLS, each up to 4000 A.
- 8** Main busbar system 3- or 4-pole.
- 9** Busbar mounting options include: Roof, base or rear panel area, both top and bottom.
- 10** "Panel to panel connection system" for all busbar systems, with no drilling required.

Form 2-4 system example 1

Power circuit-breaker panel, component overview



The components required for a component circuit-breaker panel are comprised of the enclosure, the enclosure system accessories, the compartment and the busbar systems.

Enclosure

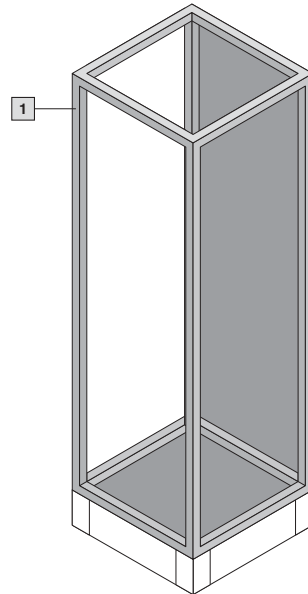

Enclosure system accessories

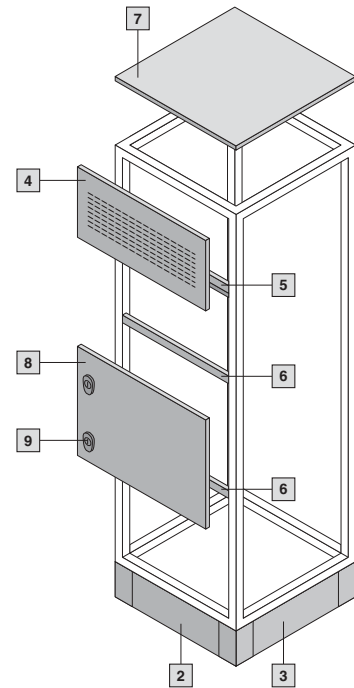

Rittal Power Engineering

The software Rittal Power Engineering from V4.0 is highly recommended for easier, faster configuration of panel types and systems. This continuously updated, graphics-oriented software tool supports customer-specific configuration and automatically produces bills of materials, CAD drawings and order lists of equipment and panels. The export interfaces mean that data and drawings are easily transmitted to other programs such as Word or Excel, or to Eplan P8.

See Cat. 32, page 1153.

Compartment

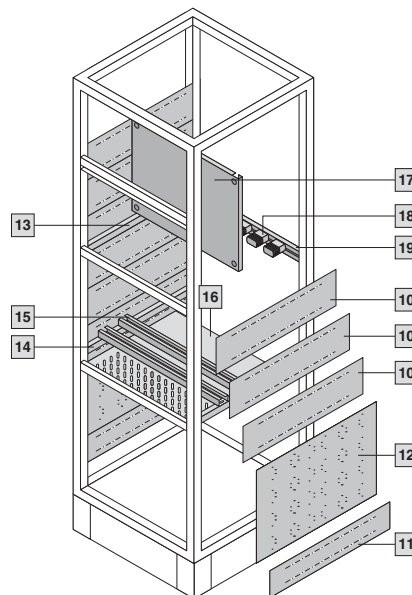

Busbar systems

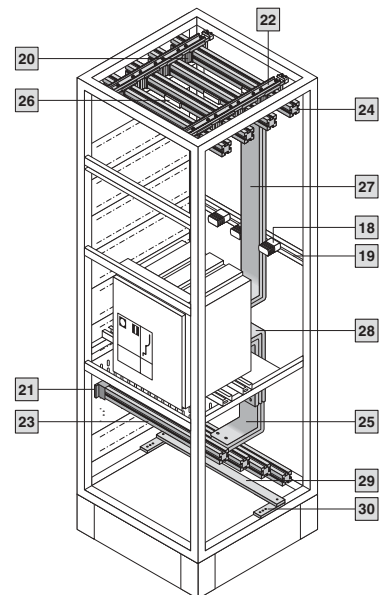

Form 2-4 system example 1

Power circuit-breaker panel, parts list



Configuration parameters:

Enclosure dimensions
W x H x D: 800 x 2200 x 800 mm,
with base/plinth 200 mm

Roof plate IP 54
Front trim panel IP 2X
Design 4B

Busbar system top
Maxi-PLS 3200, 4-pole,
in roof area,
without cover

PE bar design 80 x 10 mm

For power circuit-breaker
Mitsubishi AE, 3200 A,
4-pole, slide-in system,
positioned behind the door,
with cable connection system
Maxi-PLS 3200 A, 4-pole

Functional space divider, vented.

Enclosure		Qty.	Packs of	Model No.	Page
1	SV-TS 8 modular enclosure, W/H/D: 800 x 2200 x 800 mm	1	1	9670.828	28

Enclosure system accessories					
2	Base/plinth components, front and rear, 200 mm high	1	1	8602.800	34
3	Base/plinth trim, side, 200 mm high	1	1	8602.080	34
4	Front trim panel kit main busbar system top, IP 2X, W/H: 800 x 300/100 mm	1	1	9672.038	36
5	Horizontal roof frame bar, W: 800 mm	1	2	9672.008	38
6	Cross member for functional space divider, W: 800 mm	3	5	9671.008	36
7	Solid roof plate, W/D: 800 x 800 mm	1	1	9671.688	38
8	Partial door, W/H: 800 x 600 mm	3	1	9671.186	37
9	Lock	6	1	9671.130	37

Compartment					
10	Functional space side panel module, H/D: 200 x 800 mm	12	6	9673.082	43
11	Functional space side panel module, H/D: 150 x 800 mm	2	6	9673.085	43
12	Functional space side panel module connection space, H/D: 800 x 600 mm	2	2	9673.089	43
13	Mounting bracket for functional space divider for enclosure depth 800 mm	4	8	9673.408	45
14	Mounting bracket for ACB + functional space divider for enclosure depth 800 mm	2	2	9673.428	45
15	Power circuit-breaker support rail Form 2-4 for enclosure width 800 mm	2	2	9673.008	46
	Mounting kit for power circuit breaker	1	1	9660.970	46
16	Functional space divider for busbar system gland, vented, W/D: 800 x 800 mm	3	4	9673.478	47
	Gland plate for functional space divider, W: 800 mm	3	4	9673.508	47
17	Partial mounting plate, W/H: 800 x 600 mm	1	1	9673.686	48
18	Stacking insulator	25	6	9660.200	51
19	Support rail for stacking insulator for enclosure width 800 mm	5	4	9676.198	51

Busbar systems					
20	Busbar support Maxi-PLS 3200	6	3	9650.000	76
	Busbar support Maxi-PLS 3200	2	1	9659.000	76
21	End support Maxi-PLS 3200	6	6	9650.010	76
	End support Maxi-PLS 3200	2	2	9659.010	76
22	System attachment, Maxi-PLS 3200, 4-pole, in roof area	2	2	9650.080	76
23	Busbars Maxi-PLS 3200, 691 mm	4	1	9650.231	76
24	Busbars Maxi-PLS 3200, 799 mm	4	1	9650.251	76
25	Connection bracket for Maxi-PLS 3200, 3-pole, 3 x 100 x 10 mm, for D: 800 mm	2	1	9659.483	77
	Connection bracket for Maxi-PLS 3200, for N, 3 x 100 x 10 mm, for D: 800 mm	2	1	9659.484	77
26	U contact makers Maxi-PLS 3200, W: 100 mm	3	3	9650.180	77
	U contact maker Maxi-PLS 3200, W: 100 mm	1	1	9659.180	77
	Sliding blocks Maxi-PLS 3200, M12	8	15	9650.990	77
27	Connection kit, top, for ACB	1	1	9676.910	78
28	Connection kit, bottom, for ACB	1	1	9676.912	78
29	PE/PEN busbars 80 x 10 mm, 792 mm	1	2	9661.180	89
30	PE/PEN combination angles, flat, 40 x 10 mm	2	4	9661.240	89



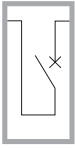

Coupling set panel



Note:

Use these examples of a coupling set panel to inspire you. The following information and tools will make your individual project planning easier:

- For diagrams and lists of parts with model numbers for this example, please see page 14/15.
- Software **Rittal Power Engineering** from Version 4.0, see Cat. 32, page 1153.

Disconnecting and connecting main busbar systems in a low-voltage switchgear is the task of a coupling set panel. For plants with several incomers, this prevents total failure and helps to reduce costs in the event of a malfunction. Similarly, the requirements governing overall short-circuit resistance may be reduced. **Overall, the investment, operating and maintenance costs are reduced, while reliability is increased.** In the event of servicing, individual busbar sections can be de-energised without having to switch off the entire system.

The coupling set panel is a combination of a power circuit-breaker panel with a busbar riser optionally arranged on the left or right. The large number of identical parts and work stages therefore **also translates into convincing cost and time benefits during assembly.**

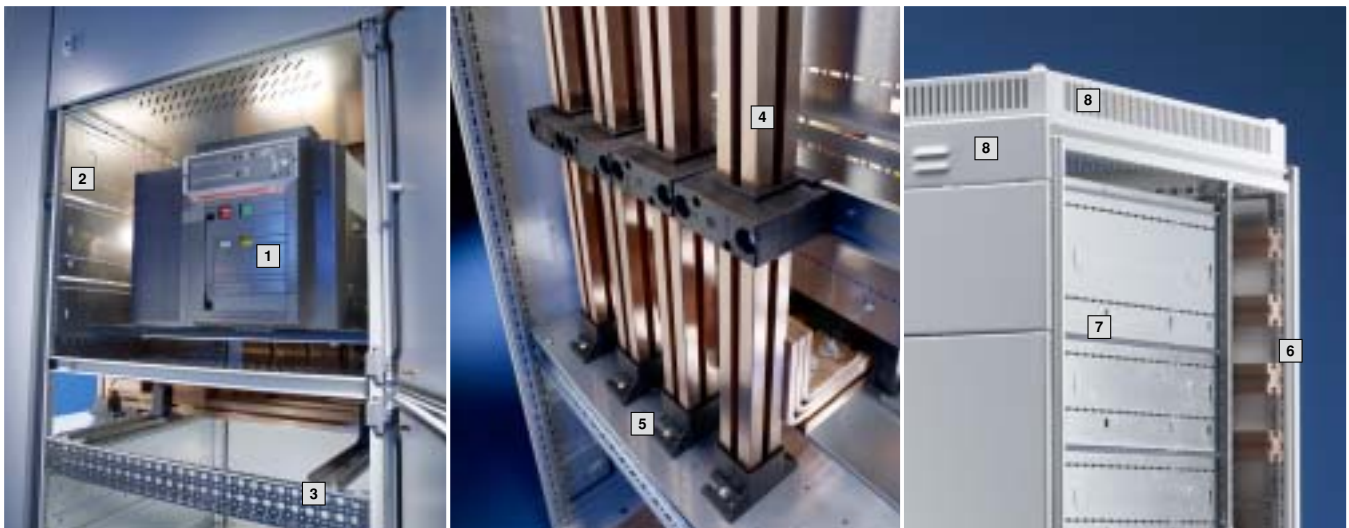

Example of a comprehensive coupling set panel design with Ri4Power Form 2-4.

Coupling switch

- 1** Connection systems for ACB power circuit-breakers from all well-known manufacturers (Siemens, ABB, Mitsubishi, Moeller, Merlin Gerin).
- 2** The same system architecture as the power circuit-breaker panel reduces the number of different items and the required assembly work.
- 3** Other system accessories facilitate virtually any variant, tailored to the required application.

Busbar riser

- 4** Version with Maxi-PLS or alternatively Flat-PLS.
- 5** Space-saving, modular and flexible arrangement of the busbar riser (on the left, alternatively on the right, or on both sides).

Busbar configuration

- 6** Main busbar routing in the vicinity of the rear panel. Alternatively, other positions are also supported.
- 7** Option of using the other compartments separately. Flexible design with standard items e.g. for controlling and monitoring the coupling switch.
- 8** Individual selection of the roof plate and front trim panel allows process-optimised population of the switchgear.

Form 2-4 system example 2

Coupling set panel, component overview



The components required for a coupling set panel are comprised of the enclosure, the enclosure system accessories, the compartment and the busbar systems.

Enclosure

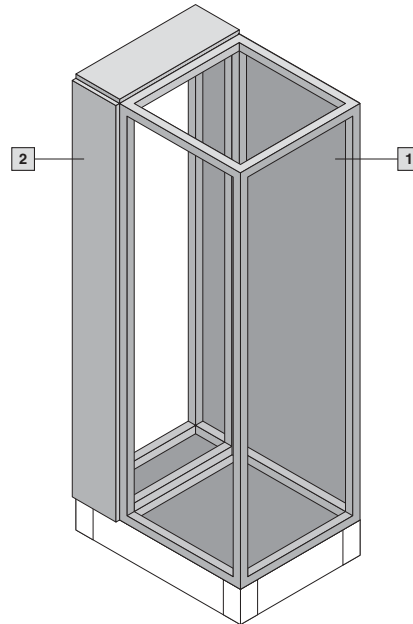

Enclosure system accessories

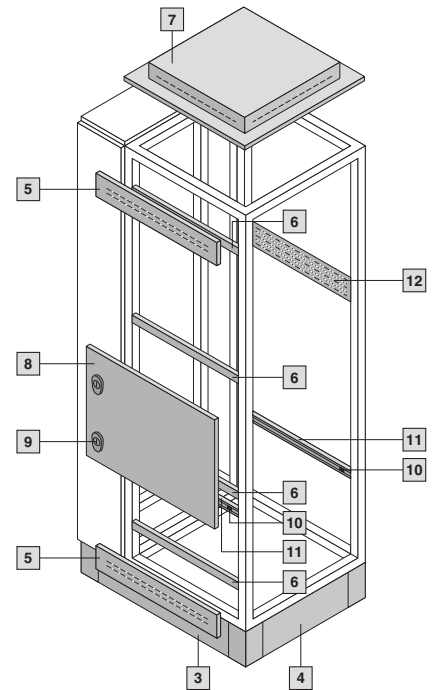

Rittal Power Engineering

The Rittal Power Engineering software from V4.0 is highly recommended for easier, faster configuration of panel types and systems. This continuously updated, graphics-oriented software tool supports customer-specific configuration and automatically produces bills of materials, CAD drawings and order lists of equipment and panels. The export interfaces mean that data and drawings are easily transmitted to other programs such as Word or Excel, or to Eplan P8.

See Cat. 32, page 1153.

Compartment

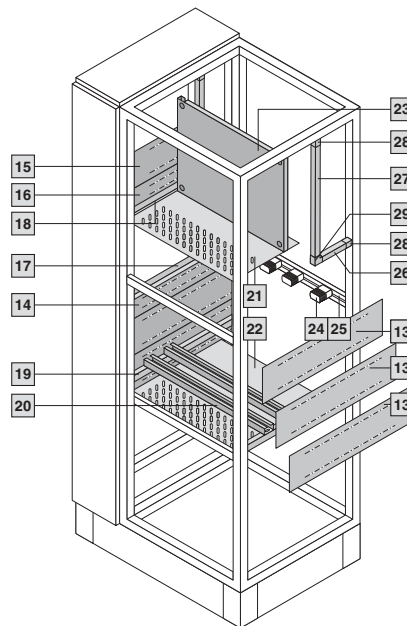

Busbar systems

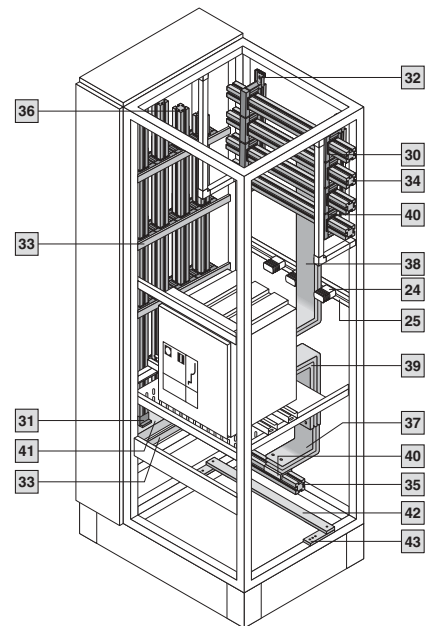

Form 2-4 system example 2

Coupling set panel, parts list



Configuration parameters:

Enclosure dimensions
W x H x D: 800 x 2200 x 800 mm,
200 x 2200 x 800 mm,
with base/plinth 200 mm

Roof plate IP 2X vented
Front trim panel IP 2X vented
Design 4B

Busbar system top
Maxi-PLS 2000, 4-pole,
in rear area,
without cover

PE bar design 80 x 10 mm

For power circuit-breakers
ABB, E2, 2500 A, fixed installation
4-pole, positioned behind the
door

Busbar system, bottom
Maxi-PLS 2000, 4-pole,
directly underneath the power
circuit-breaker

Functional space divider, vented.

¹⁾ Cat. 32

Enclosure		Qty.	P. of	Model No.	Page
1	SV-TS 8 modular enclosure, W/H/D: 800 x 2200 x 800 mm	1	1	9670.828	28
2	SV-TS 8 busbar enclosure, W/H/D: 200 x 2200 x 800 mm	1	1	9670.228	32

Enclosure system accessories

3	Base/plinth components, front and rear, 200 mm high	1	1	8602.000	34
4	Base/plinth trim, side, 200 mm high	1	1	8602.080	34
5	Front trim panel kit, IP 2X, W/H: 800 x 100 mm	1	1	9671.038	35
6	Cross member for functional space divider, W: 800 mm	6	5	9671.008	36
7	Roof plate, vented, IP 2X, W/D: 800 x 800 mm	1	1	9659.535	38
	Partial door, W/H: 800 x 200 mm	1	1	9671.182	37
	Partial door, W/H: 800 x 300 mm	2	1	9671.183	37
8	Partial door, W/H: 800 x 600 mm	2	1	9671.186	37
9	Lock	7	1	9671.130	37
	Baying connectors, external	6	6	8800.490	35
	Angular baying bracket TS/TS	4	4	8800.430	35
	U nut M6 for punched rail	8	20	4179.000	39
10	Support bracket for PS punched sections without mounting flange	4	24	4183.000	39
11	PS punched section without mounting flange, 23 x 73 mm, for enclosure width 800 mm	2	4	4377.000	998 ¹⁾
12	TS punched section with mounting flange, 23 x 73 mm, for enclosure width 800 mm	1	4	8612.580	995 ¹⁾

Compartment

13	Functional space side panel module, H/D: 200 x 800 mm	13	6	9673.082	43
14	Functional space side panel module, H/D: 100 x 800 mm	2	6	9673.081	43
15	Functional space side panel module, H/D: 200 x 600 mm	4	6	9673.062	43
16	Functional space side panel module, H/D: 100 x 600 mm	2	6	9673.061	43
17	Mounting bracket for functional space divider for enclosure depth 800 mm	4	8	9673.408	45
18	Mounting bracket for functional space divider for enclosure depth 600 mm	6	8	9673.406	45
19	Mounting bracket for ACB + functional space divider for enclosure depth 800 mm	2	2	9673.428	45
20	Power circuit-breaker support rail Form 2-4 for enclosure width 800 mm	2	2	9673.008	46
	Mounting kit for power circuit breaker	1	1	9660.970	46
21	Functional space divider, vented, W/D: 800 x 600 mm	2	4	9673.485	46
22	Functional space divider for busbar system gland, vented, W/D: 800 x 800 mm	4	4	9673.478	47
	Gland plate for compartment divider, W: 800 mm	4	4	9673.508	47
23	Partial mounting plate, W/H: 800 x 200 mm	1	1	9673.682	48
	Partial mounting plate, W/H: 800 x 300 mm	2	1	9673.683	48
24	Stacking insulator	5	6	9660.200	51
25	Support rail for stacking insulator for enclosure width 800 mm	1	4	9676.198	51
26	Mini-TS profile, 17 x 15.5 mm, L: 137.5 mm	2	12	9673.920	49
27	Mini-TS profile, 17 x 15.5 mm, L: 487.5 mm	2	12	9673.953	49
28	Frame connector piece for Mini-TS profile	4	24	9673.901	50
29	Corner connector for Mini-TS profile	2	10	9673.902	50

Busbar systems

	Busbar support Maxi-PLS 2000	24	3	9640.000	74
30	Busbar support Maxi-PLS 2000, suitable for top-mounting	8	3	9640.160	74
31	End support Maxi-PLS 2000	4	6	9640.010	74
32	System attachment Maxi-PLS 2000/4, rear section, frame chassis	2	2	9640.098	74
33	System attachment Maxi-PLS 2000/4, coupling set panel	6	2	9649.078	74
34	Busbars Maxi-PLS 2000 725 mm	4	1	9640.241	74
35	Busbars Maxi-PLS 2000 799 mm	4	1	9640.251	74
36	Busbars Maxi-PLS 2000, special length 1299 mm	1	1	9640.368	on req.
	Busbars Maxi-PLS 2000, special length 1399 mm	1	1	9640.368	on req.
	Busbars Maxi-PLS 2000, special length 1499 mm	1	1	9640.368	on req.
	Busbars Maxi-PLS 2000, special length 1599 mm	1	1	9640.368	on req.
37	Connection bracket for Maxi-PLS 1600/2000, 3-pole, 2 x 100 x 10 mm	1	1	9640.473	75
	Connection bracket for Maxi-PLS 1600/2000, for N, 2 x 100 x 10 mm	1	1	9640.474	75
38	Connection kit, top, for ACB	1	1	9676.910	78
39	Connection kit, bottom, for ACB	1	1	9676.912	78
40	U contact makers Maxi-PLS 2000, W: 100 mm	8	3	9640.180	75
	Corner bracket Maxi-PLS 2000	4	1	9640.700	94
	Sliding blocks Maxi-PLS 2000, M10	16	15	9640.980	75
	Connection kit Maxi-PLS 2000/3, coupling set in the rear section	1	1	9660.313	94
	Connection kit Maxi-PLS 2000/N, coupling set in the rear section	1	1	9660.314	94
41	Mounting kit for coupling set for enclosure depth 800 mm	1	1	9674.198	94
42	PE/PEN busbars 80 x 10 mm, 992 mm	1	2	9661.100	89
43	PE/PEN combination angles, flat, 40 x 10 mm	2	4	9661.240	89



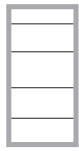

Form 2-4 system example 3

Outgoing panel



Installation of switchgear, power supply outlets or controllers – the **application areas of the outgoing panel are very versatile**. With multifunctional components, the individual compartments may be quickly assembled and configured to suit your requirements. The busbar distributor system may be positioned adjacent to, behind or directly in the compartments and is easily and safely connected to the main busbar systems using system components. **The benefits are convincing, both in terms of assembly and during subsequent operation:** Simple project planning, fast assembly, flexible adaptation and a high level of safety.

Note:

Use these examples of an outgoing panel to inspire you. The following information and tools will make project planning easier:

- For diagrams and lists of parts with model numbers for this example, please see page 18/19.
- Software **Rittal Power Engineering** from Version 4.0, set Cat. 32, page 1153.

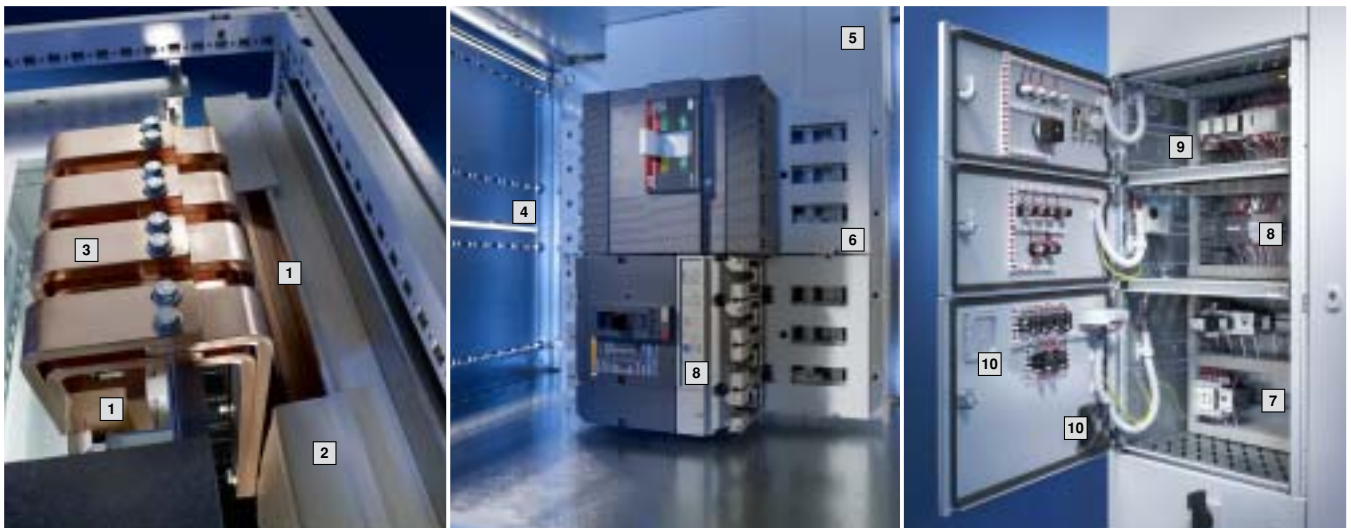

Example of a comprehensive outgoing panel design with Ri4Power Form 2-4.

Distribution busbars

- 1** RiLine60 is ideal for small rated currents. Alternatively, for higher currents, Maxi-PLS or Flat-PLS may be used for the main busbar.
- 2** Simple insulation and cover with standard parts.
- 3** T-connection kits for connecting main and distributor bar systems.

Compartments with power outlet

- 4** Interior installation individual, flexible and tailored to your requirements.
- 5** Distributor busbar arrangement of the indoor bar system, alternatively:
 - Behind the compartments/partial mounting plates
 - At the side adjacent to the modular outgoing panel to the side infeed into the compartments.
- 6** RiLine60 circuit-breaker adaptor for time-saving, maintenance-friendly installation of power circuit-breakers up to 630 A.

Compartments with control units

- 7** Use of control units to your individual requirements.
- 8** For all well-known brands of switchgear and controllers from Siemens, ABB, Mitsubishi, Moeller, Merlin Gerin.
- 9** Space-optimised configuration thanks to fine graduation of the compartment heights.
- 10** Rittal system accessories provide comprehensive installation and numerous design variants depending on the intended application.

Form 2-4 system example 3

Outgoing panel, component overview



The components required for an outgoing panel are comprised of the enclosure, the enclosure system accessories, the compartment and the busbar systems.

Enclosure

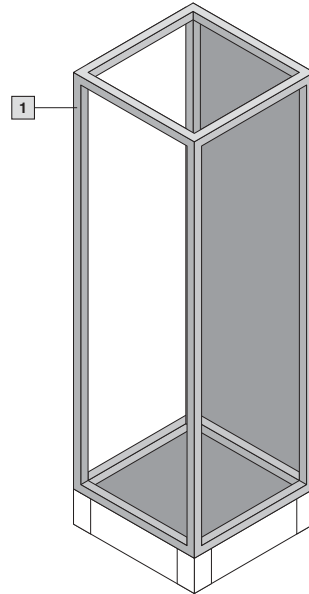

Enclosure system accessories

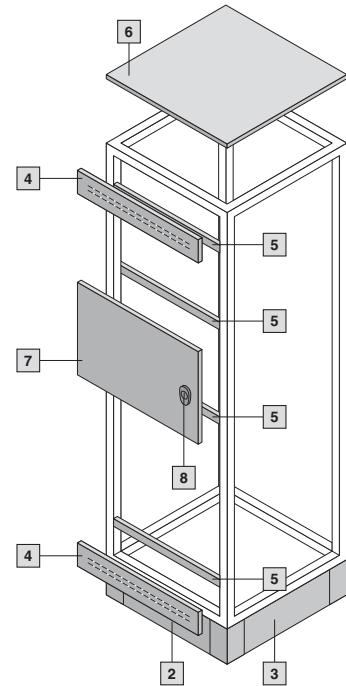

Rittal Power Engineering

The Rittal Power Engineering software from V4.0 is highly recommended for easier, faster configuration of panel types and systems. This continuously updated, graphics-oriented software tool supports customer-specific configuration and automatically produces bills of materials, CAD drawings and order lists of equipment and panels. The export interfaces mean that data and drawings are easily transmitted to other programs such as Word or Excel, or to Eplan P8.

See Cat. 32, page 1153.

Compartment

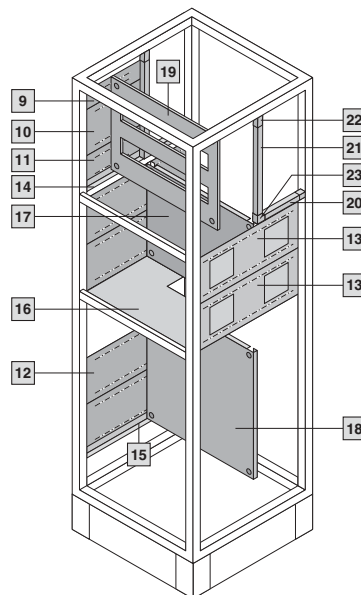

Busbar systems

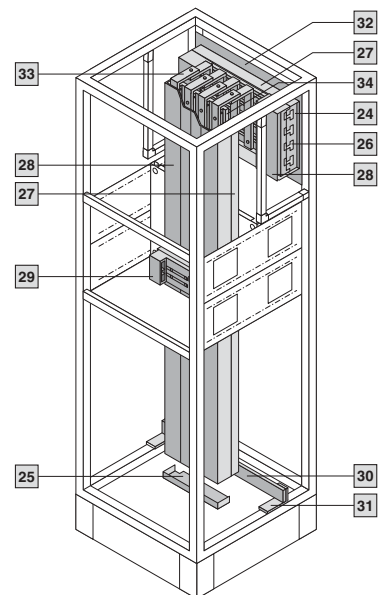

Form 2-4 system example 3

Outgoing panel, parts list



Configuration parameters:

Enclosure dimensions
W x H x D: 600 x 2200 x 600 mm,
with base/plinth 200 mm

Roof plate IP 54, solid
Front trim panel IP 54, solid
Design 4A

Main busbar system
RiLine60, PLS 1600, 4-pole,
in rear section, top,
with cover

PE bar design 30 x 10 mm

Distributor busbar system
RiLine60, PLS 1600, 4-pole,
in compartment (indoor),
with cover

Functional space divider for
RiLine60, solid

Device-specific design of the
compartments and adaptors

Enclosure	Qty.	Packs of	Model No.	Page
1 SV-TS 8 mdoular enclosure, W/H/D: 600 x 2200 x 600 mm	1	1	9670.626	28

Enclosure system accessories

2 Base/plinth components, front and rear, 200 mm high	1	1	8602.600	34
3 Base/plinth trim, side, 200 mm high	1	1	8602.060	34
4 Front trim panel kit IP 54, W/H: 600 x 100 mm	1	1	9671.016	35
5 Cross member for functional space divider, W: 600 mm	7	5	9671.006	36
6 Solid roof plate, W/D: 600 x 600 mm	1	1	9671.666	38
Partial door, W/H: 600 x 150 mm	1	1	9671.161	37
7 Partial door, W/H: 600 x 300 mm	2	1	9671.163	37
Partial door, W/H: 600 x 400 mm	1	1	9671.164	37
Partial door, W/H: 600 x 600 mm	1	1	9671.166	37
Partial door, W/H: 600 x 250 mm	1	1	9671.162	37
8 Lock	7	1	9671.130	37

Compartment configuration

9 Functional space side panel module, H/D: 100 x 425 mm	2	6	9673.051	43
10 Functional space side panel module, H/D: 200 x 425 mm	1	6	9673.052	43
11 Functional space side panel module, H/D: 150 x 425 mm	1	6	9673.055	43
Functional space side panel module, H/D: 100 x 600 mm	4	6	9673.061	43
12 Functional space side panel module, H/D: 200 x 600 mm	6	6	9673.062	43
Functional space side panel module, H/D: 150 x 600 mm	1	6	9673.065	43
Functional space side panel module with gland plate, H/D: 200 x 425 mm	1	6	9673.152	43
Functional space side panel module with gland plate, H/D: 150 x 425 mm	1	6	9673.155	43
13 Functional space side panel module with gland plate, H/D: 200 x 600 mm	6	6	9673.162	43
Functional space side panel module with gland plate, H/D: 150 x 600 mm	1	6	9673.165	43
14 Mounting bracket for functional space divider for enclosure depth 425 mm	6	8	9673.405	45
15 Mounting bracket for functional space divider for enclosure depth 600 mm	8	8	9673.406	45
16 Functional space divider for RiLine60, solid, W/D: 600 x 400 mm	7	4	9673.450	47
Partial mounting plate, W/H: 600 x 150 mm	1	1	9673.661	48
17 Partial mounting plate, W/H: 600 x 300 mm	2	1	9673.663	48
Partial mounting plate, W/H: 600 x 400 mm	1	1	9673.664	48
18 Partial mounting plate, W/H: 600 x 600 mm	1	1	9673.666	48
Partial mounting plate, W/H: 600 x 250 mm	1	1	9673.667	48
19 Support frame for DIN rail-mounted devices, W: 600 mm, 2-row	1	1	9674.762	49
20 Mini-TS profile, 17 x 15.5 mm, L: 62.5 mm	2	12	9673.915	49
21 Mini-TS profile, 17 x 15.5 mm, L: 437.5 mm	2	12	9673.952	49
22 Frame connector piece for Mini-TS profile	4	24	9673.901	50
23 Corner connector for Mini-TS profile	2	10	9673.902	50

Busbar systems

24 RiLine60 busbar support PLS 1600 PLUS	7	4	9342.004	66
25 RiLine60 end cover for PLS 1600 PLUS	1	2	9342.074	66
26 Busbar PLS 1600 A, 495 mm long	4	3	3527.000	66
27 RiLine60 base tray section for PLS 1600 PLUS	2	2	9342.134	67
28 RiLine60 cover section for PLS 1600 PLUS, L: 1100 mm	2	2	9340.214	67
RiLine60 support panel PLS 1600 PLUS	14	5	9340.224	67
Circuit-breaker component adaptor 160 A, 690 V, outlet at bottom, 3-pole	1	1	9342.510	62
29 Circuit-breaker component adaptor 160 A, 690 V, outlet at bottom, 4-pole	2	1	9342.514	70
Circuit-breaker component adaptor 250 A, 690 V, outlet at bottom, 4-pole	2	1	9342.614	70
Circuit-breaker component adaptor 630 A, 690 V, outlet at bottom, 3-pole	3	1	9342.710	63
Insert strip, W: 25 mm, for SV 9342.700/.710	4	4	9342.720	96
30 PE/PEN busbar, 30 x 10 mm, for enclosure width 600 mm	1	2	9661.360	89
31 PE/PEN combination angles, 30 x 10 mm	2	4	9661.230	89
32 System attachment for RiLine60 for enclosure width 600 mm	1	1	9674.006	92
33 T-connector RiLine60, 1600 A, 4-pole, indoor, PLS 1600	1	1	9675.166	91
34 Distributor bar PLS 1600, indoor, for enclosure height 2200 mm	4	1	9675.242	92



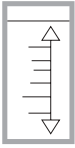

Form 2-4 system example 4

Cable chamber



The distribution of cables into and out of the individual compartments is the task of the cable chamber. Depending on the main busbar system chosen, **cable entry may be either from below, above, or below and above.** There are various cable entry glands to choose from for the roof plate. The main busbar system is covered in a contact hazard-proof manner, depending on the type and configuration. Ri4Power Form 2-4 offers every conceivable option for designing PE and N distributor bars. In each case, **the equipment manufacturer's requirements are effectively met to perfection.**

Note:

Use these examples of a cable chamber to inspire you. The following information and tools will make project planning easier:

- For diagrams and lists of parts with model numbers for this example, please see page 22/23.
- Software **Rittal Power Engineering** from Version 4.0, see Cat. 32, page 1153.

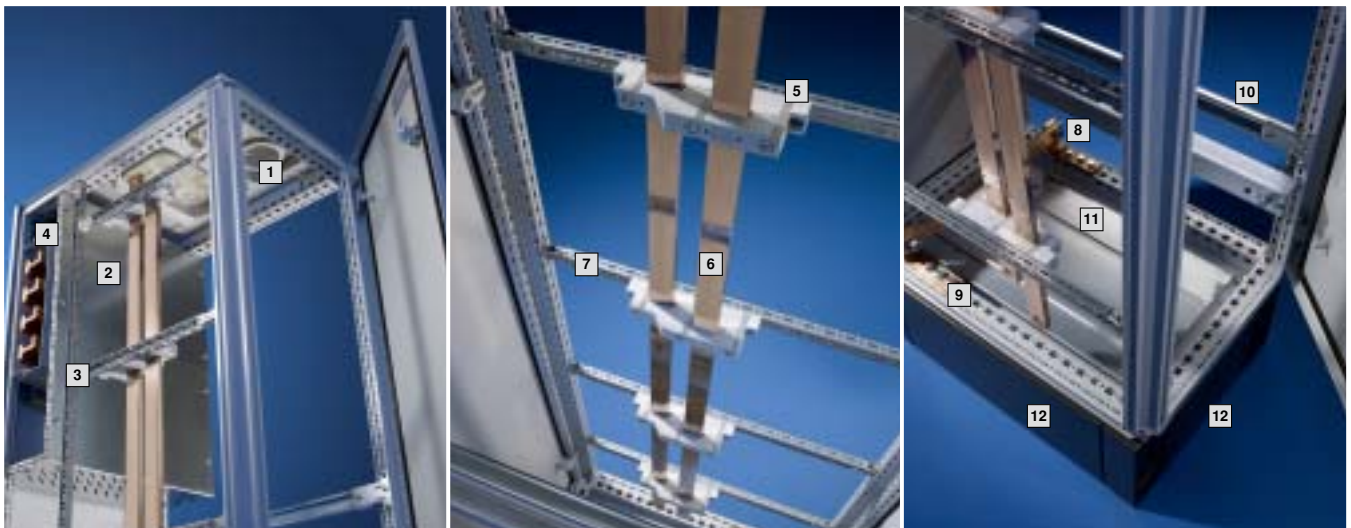

Example of a comprehensive cable chamber design with Ri4Power Form 2-4.

SV-TS 8 cable chamber enclosure

- 1 Roof plate for cable gland plates, cable entry glands.
- 2 Cover of the main busbar system.
- 3 Mini-TS profiles as an auxiliary design.
- 4 Main busbar system with RiLine60, alternatively with Maxi-PLS or Flat-PLS.

PE and N distributor busbars

- 5 Busbar supports for PE and N distributor busbars.
- 6 Distributor busbar to match the enclosure heights.
- 7 Supporting structure of Mini-TS sections for individual attachment.

PE/PEN, cable entry, base/plinth

- 8 PE/PEN busbar tailored to the enclosure width. Configurable in various cross-sections.
- 9 PE/PEN combination angles for attaching the PE bar and incorporating the TS 8 enclosure into the protective measure.
- 10 C rails for cable attachment, alternatively cable clamp rail from right-angle section.
- 11 Gland plates divided in the depth.
- 12 Base/plinth components, front and rear base/plinth trim, side.

Form 2-4 system example 4

Cable chamber, component overview



The components required for a cable chamber are comprised of the enclosure, the enclosure system accessories, the compartment and the busbar systems.

Enclosure

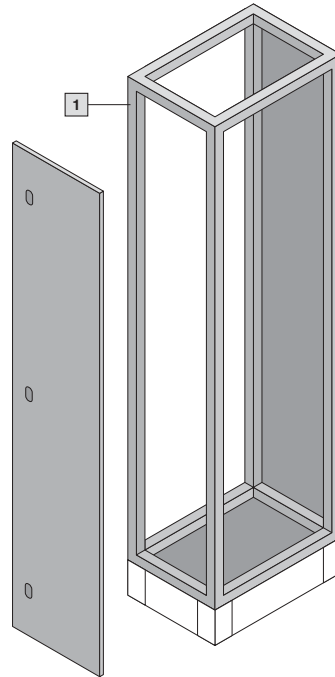

Enclosure system accessories

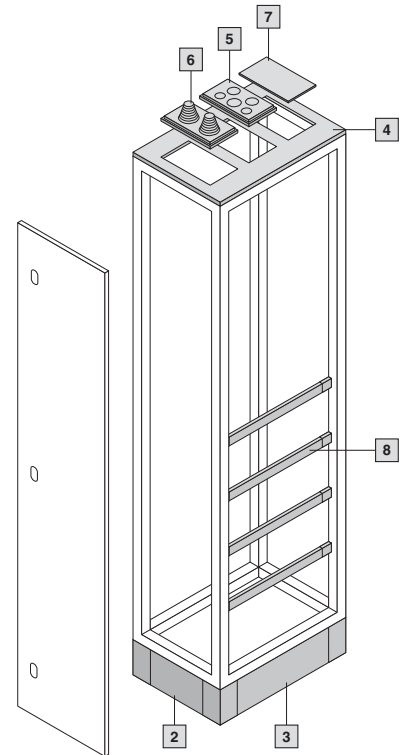

Rittal Power Engineering

The Rittal Power Engineering software from V4.0 is highly recommended for easier, faster configuration of panel types and systems. This continuously updated, graphics-oriented software tool supports customer-specific configuration and automatically produces bills of materials, CAD drawings and order lists of equipment and panels. The export interfaces mean that data and drawings are easily transmitted to other programs such as Word or Excel, or to Eplan P8.

See Cat. 32, page 1153.

Compartment

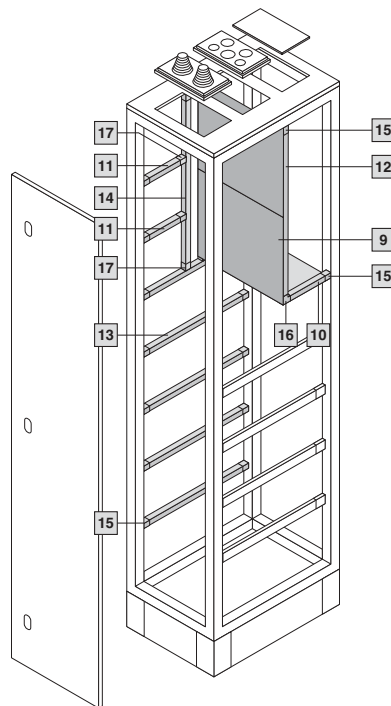

Busbar systems

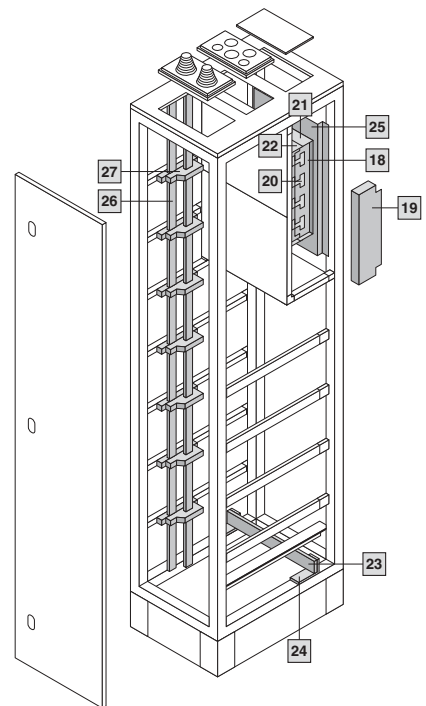

Form 2-4 system example 4

Cable chamber, parts list



Configuration parameters:

Enclosure dimensions
W x H x D: 400 x 2200 x 600 mm,
with base/plinth 200 mm

Roof plate for cable gland plates
Type 4A

Main busbar system
RiLine60, PLS 1600, 4-pole,
in rear section, top,
with cover

PE bar design 30 x 10 mm

PE/N distributor bar version
PE + N

PE 30 x 10 mm
N 30 x 10 mm

Cable clamp rail
C rail

Enclosure		Qty.	Packs of	Model No.	Page
1	SV-TS 8 cable chamber enclosure, W/H/D: 400 x 2200 x 600 mm	1	1	9670.436	31

Enclosure system accessories					
2	Base/plinth components, front and rear, 200 mm high	1	1	8602.400	34
3	Base/plinth trim, side, 200 mm high	1	1	8602.060	34
4	Roof plate for cable gland plates, W/D: 400 x 600 mm	1	1	9671.546	38
5	ISV cable entry gland, M25/32/40/50/63	1	1	9665.760	39
6	ISV cable entry gland, with entry fittings	1	1	9665.780	39
7	ISV cable entry gland, solid	1	4	9665.785	39
8	C rails, for TS 8, W/D: 600 mm	4	4	9660.210	Cat. 32, 454

Compartment					
9	Cover plate, main busbar system, W: 400 mm	1	2	9673.540	44
10	Mini-TS profile, 17 x 15.5 mm, L: 62.5 mm	2	12	9673.915	49
11	Mini-TS profile, 17 x 15.5 mm, L: 262.5 mm	2	12	9673.940	49
12	Mini-TS profile, 17 x 15.5 mm, L: 487.5 mm	2	12	9673.953	49
13	Mini-TS profile, 17 x 15.5 mm, L: 462.5 mm	5	12	9673.960	49
14	Mini-TS profile, 17 x 15.5 mm, L: 662.5 mm	1	12	9673.980	49
15	Frame connector piece for Mini-TS profile	17	24	9673.901	50
16	Corner connector for Mini-TS profile	2	10	9673.902	50
17	T-connector piece for Mini-TS profile	3	24	9673.903	50

Busbar systems					
18	RiLine60 busbar support PLS 1600 PLUS	2	4	9342.004	66
19	RiLine60 end cover for PLS 1600 PLUS	1	2	9342.074	66
20	Busbar PLS 1600 A, 495 mm long	4	3	3527.000	66
21	RiLine60 base tray section for PLS 1600 PLUS	1	2	9342.134	67
22	RiLine60 cover section for PLS 1600 PLUS, L: 1100 mm	1	2	9340.214	67
	RiLine60 support panel PLS 1600 PLUS	2	5	9340.224	67
23	PE/PEN busbar, 30 x 10 mm, for enclosure width 400 mm	1	2	9661.340	89
24	PE/PEN combination angles, 30 x 10 mm	2	4	9661.230	89
25	System attachment for RiLine60 for enclosure width 400 mm	1	1	9674.004	92
26	Distributor bar 30 x 10 mm, indoor, for enclosure height 2200 mm	2	1	9675.222	92
27	Busbar support N/PE, 2-pole	7	4	9340.040	88



Top enclosure, top flexible, top efficient: TS 8

With the TS 8 enclosure system, every enclosure is a specialist – however exceptional the task. By combining Ri4Power and busbar components with general system accessories, it is possible to create infinite possibilities in the separation of Form 2-4 – the TS 8 system punching is the key.

Form 2-4 enclosures

Benefits of the TS 8 system platform

System platform TS 8 Top enclosure system



The enclosure system with the efficiency of infinite possibilities. Unbeatable in terms of space utilisation, bayability, interior installation and fast assembly.



Universal interior installation: Frame sections, slotted on a 25 mm pitch pattern. Two symmetrical levels for maximum space utilisation in the width and depth.



Uninhibited access from all sides: Doors are possible at the front, rear and sides. 4-point hinge and lock system.



Bayable on all sides: Around corners, to the front, rear, left, right and if necessary, even upwards.

Ri4Power configuration



Ri4Power system solutions are based on the TS 8 Top enclosure system. Winning features: Compatibility with all power distribution components.



The proven TS 8 pitch pattern is used for many Ri4Power Form 2-4 components, thus enabling the use of TS 8 system accessories.



Undoubtedly convincing – **RiLine60:** effective space utilisation, extensive safety back-ups, all-round contact hazard protection, safe and fast contacting.



Low voltage switchgear with **Maxi-PLS and Flat-PLS.** Future-oriented, type-tested modular systems offer exceptional fast assembly and safety.

Standard accessories



Rittal system accessories for individuality, perfection and speed when solving your tasks.



Base/plinth components (front and rear) combined with trim panels (side) or used to link two base/plinths.



Quick assembly: Door-operated switch and lights – simply fit and secure – and it's done.



Roof plate options for every type of cable entry and ventilation.

Form 2-4 enclosures

SV-TS 8 modular enclosures (height 1800 mm)

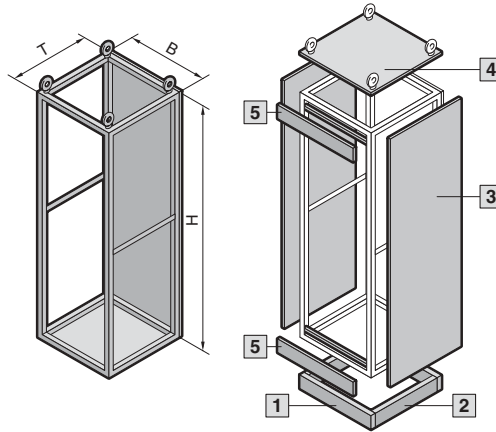

Modular enclosure frame for installation with partial doors and internal separation.

Material:
Sheet steel
Enclosure frame, rear panel and gland plates: 1.5 mm

Surface finish:
Enclosure frame:
Dipcoat-primed
Rear panel:
Dipcoat-primed,
powder-coated in textured
RAL 7035 on the outside
Gland plates: Zinc-plated

Protection category:
Up to IP 54,
depending on the roof plate,
front trim panels and side panel.

Supply includes:
Enclosure frame with rear panel
and gland plates.

+ **Accessories:**
System accessories,
see Cat. 32, page 890.

Inspection:
Type-tested in accordance with
IEC 60 439-1.

Detailed drawings,
see page 104.

Technical information,
see page 107 – 110.

Width (B) mm	Packs of	400	600	800	Page
Height (H) mm		1800	1800	1800	
Depth (T) mm		600	600	600	
Model No. SV	1	9670.486	9670.686	9670.886	
Weight (kg)		45.0	49.0	58.5	

Base/plinth						
1 Components front and rear	Height 100 mm	1 set	8601.400	8601.600	8601.800	34
	Height 200 mm	1 set	8602.400	8602.600	8602.800	34
2 Trim panels sides	Height 100 mm	1 set	8601.060	8601.060	8601.060	34
	Height 200 mm	1 set	8602.060	8602.060	8602.060	34

Also required						
3 Side panels for protection category	IP 55	2	8186.235	8186.235	8186.235	33
	IP 2X	2	9671.986	9671.986	9671.986	33
	Upgrade kit for side panels IP 2X	IP 43	2 sets ¹⁾	9671.996	9671.996	9671.996
4 Roof plates for protection category	IP 55	1	9671.646	9671.666	9671.686	38
	IP 43	1	9671.746	9671.766	9671.786	38
	IP 2X	1	–	9660.235	9660.245	38
Roof plates for cable entry gland		1	9671.546	9665.903	9671.586	38
5 Front trim panels for protection category	IP 54	1 set	9671.014	9671.016	9671.018	35
	IP 2X	1 set	9671.034	9671.036	9671.038	35
	Upgrade kit for front panels IP 2X	IP 43	1 set	9671.044	9671.046	9671.048
Partial doors for clearance height with front trim panel 100/100 mm		1	9671.156	9671.176	9671.196	37
5 Front trim panels, top 300 mm/ bottom 100 mm for protection category	IP 54	1 set	9672.014	9672.016	9672.018	36
	IP 2X	1 set	9672.034	9672.036	9672.038	36
	Front trim panels, top 100 mm/ bottom 300 mm for protection category	IP 54	1 set	9672.024	9672.026	9672.028
	IP 2X	1 set	9672.044	9672.046	9672.048	36
Upgrade kit for front trim panels 300/100 mm IP 2X	IP 43	1 set	9672.054	9672.056	9672.058	36
Partial doors for clearance height with front trim panel 300/100 mm		1	–	–	–	37
Partial doors for modular configuration		1	■	■	■	37
Angular baying brackets		4		8800.430		35
Baying connectors, external		6		8800.490		35

Accessories	
Enclosure configuration	33 – 39
Compartment configuration	42 – 51
ISV components	52 – 87

¹⁾ Pack sufficient for 1 pack of side panels.

Form 2-4 enclosures

SV-TS 8 modular enclosures (height 2000 mm)

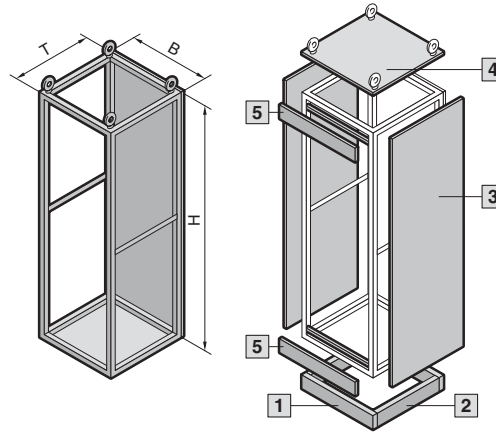

Modular enclosure frame for installation with partial doors and internal separation.

Material:
Sheet steel
Enclosure frame, rear panel and gland plates: 1.5 mm

Surface finish:
Enclosure frame: Dipcoat-primed
Rear panel: Dipcoat-primed, powder-coated in textured RAL 7035 on the outside
Gland plates: Zinc-plated

Protection category:
Up to IP 54, depending on the roof plate, front trim panels and side panel.

Supply includes:
Enclosure frame with rear panel and gland plates.

Accessories:
System accessories, see Cat. 32, page 890.

Inspection:
Type-tested in accordance with IEC 60 439-1.

Detailed drawings,
see page 104.

Technical information,
see page 107 – 110.

Width (B) mm	Packs of	400	600	800	400	600	800	Page
Height (H) mm		2000	2000	2000	2000	2000	2000	
Depth (T) mm		600	600	600	800	800	800	
Model No. SV	1	9670.406	9670.606	9670.806	9670.408	9670.608	9670.808	
Weight (kg)		47.0	51.0	61.0	56.0	61.0	72.0	

Base/plinth									
1 Components front and rear	Height 100 mm	1 set	8601.400	8601.600	8601.800	8601.400	8601.600	8601.800	34
	Height 200 mm	1 set	8602.400	8602.600	8602.800	8602.400	8602.600	8602.800	34
2 Trim panels sides	Height 100 mm	1 set	8601.060	8601.060	8601.060	8601.080	8601.080	8601.080	34
	Height 200 mm	1 set	8602.060	8602.060	8602.060	8602.080	8602.080	8602.080	34
Also required									
3 Side panels for protection category	IP 55	2	8106.235	8106.235	8106.235	8108.235	8108.235	8108.235	33
	IP 2X	2	9671.906	9671.906	9671.906	9671.908	9671.908	9671.908	33
	Upgrade kit for side panels IP 2X	IP 43	2 sets ¹⁾	9671.996	9671.996	9671.996	9671.998	9671.998	33
4 Roof plates for protection category	IP 55	1	9671.646	9671.666	9671.686	9671.648	9671.668	9671.688	38
	IP 43	1	9671.746	9671.766	9671.786	9671.748	9671.768	9671.788	38
	IP 2X	1	–	9660.235	9660.245	–	9659.525	9659.535	38
5 Front trim panels for protection category	IP 54	1 set	9671.546	9665.903	9671.586	9671.548	9671.568	9671.588	38
	IP 54	1 set	9671.014	9671.016	9671.018	9671.014	9671.016	9671.018	35
	IP 2X	1 set	9671.034	9671.036	9671.038	9671.034	9671.036	9671.038	35
Upgrade kit for front panels IP 2X	IP 43	1 set	9671.044	9671.046	9671.048	9671.044	9671.046	9671.048	35
	Partial doors for clearance height with front trim panel 100/100 mm	1	9671.158	9671.178	9671.198	9671.158	9671.178	9671.198	37
5 Front trim panels, top 300 mm/ bottom 100 mm for protection category	IP 54	1 set	9672.014	9672.016	9672.018	9672.014	9672.016	9672.018	36
	IP 2X	1 set	9672.034	9672.036	9672.038	9672.034	9672.036	9672.038	36
Front trim panels, top 100 mm/ bottom 300 mm for protection category	IP 54	1 set	9672.024	9672.026	9672.028	9672.024	9672.026	9672.028	36
	IP 2X	1 set	9672.044	9672.046	9672.048	9672.044	9672.046	9672.048	36
Upgrade kit for front trim panels 300/100 mm IP 2X	IP 43	1 set	9672.054	9672.056	9672.058	9672.054	9672.056	9672.058	36
Partial doors for clearance height with front trim panel 300/100 mm	1	9671.156	9671.176	9671.196	9671.156	9671.176	9671.196	37	
Partial doors for modular configuration	1	■	■	■	■	■	■	37	
Angular baying brackets	4				8800.430			35	
Baying connectors, external	6				8800.490			35	

Accessories									
Enclosure configuration									33 – 39
Compartment configuration									42 – 51
ISV components									52 – 87

¹⁾Pack sufficient for 1 pack of side panels.

System overview Page 9 – 23

Form 2-4 enclosures

SV-TS 8 modular enclosures (height 2200 mm)

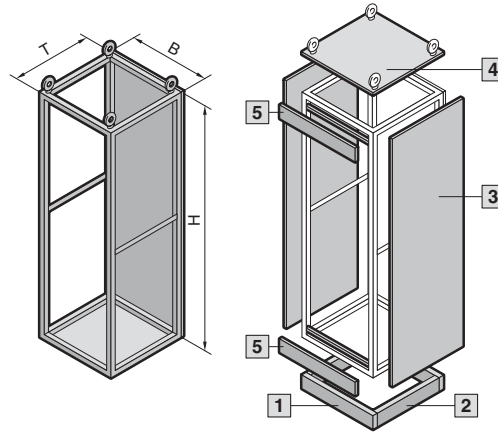

Modular enclosure frame for installation with partial doors and internal separation.

Material:
Sheet steel
Enclosure frame, rear panel and gland plates: 1.5 mm

Surface finish:
Enclosure frame: Dipcoat-primed
Rear panel: Dipcoat-primed, powder-coated in textured RAL 7035 on the outside
Gland plates: Zinc-plated

Protection category:
Up to IP 54, depending on the roof plate, front trim panels and side panel.

Supply includes:
Enclosure frame with rear panel and gland plates.

Accessories:
System accessories, see Cat. 32, page 890.

Inspection:
Type-tested in accordance with IEC 60 439-1.

Detailed drawings,
see page 104.

Technical information,
see page 107 – 110.

Width (B) mm	Packs of	400	600	800	400	600	800	Page
Height (H) mm		2200	2200	2200	2200	2200	2200	
Depth (T) mm		600	600	600	800	800	800	
Model No. SV	1	9670.426	9670.626	9670.826	9670.428	9670.628	9670.828	
Weight (kg)		49.0	53.0	64.0	58.0	64.0	75.0	

Base/plinth									
1 Components front and rear	Height 100 mm	1 set	8601.400	8601.600	8601.800	8601.400	8601.600	8601.800	34
	Height 200 mm	1 set	8602.400	8602.600	8602.800	8602.400	8602.600	8602.800	34
2 Trim panels sides	Height 100 mm	1 set	8601.060	8601.060	8601.060	8601.080	8601.080	8601.080	34
	Height 200 mm	1 set	8602.060	8602.060	8602.060	8602.080	8602.080	8602.080	34

Also required									
3 Side panels for protection category	IP 55	2	8126.235	8126.235	8126.235	8128.235	8128.235	8128.235	33
	IP 2X	2	9671.926	9671.926	9671.926	9671.928	9671.928	9671.928	33
	Upgrade kit for side panels IP 2X	IP 43	2 sets ¹⁾	9671.996	9671.996	9671.996	9671.998	9671.998	9671.998
4 Roof plates for protection category	IP 55	1	9671.646	9671.666	9671.686	9671.648	9671.668	9671.688	38
	IP 43	1	9671.746	9671.766	9671.786	9671.748	9671.768	9671.788	38
	IP 2X	1	–	9660.235	9660.245	–	9659.525	9659.535	38
Roof plates for cable entry gland		1	9671.546	9665.903	9671.586	9671.548	9671.568	9671.588	38
5 Front trim panels for protection category	IP 54	1 set	9671.014	9671.016	9671.018	9671.014	9671.016	9671.018	35
	IP 2X	1 set	9671.034	9671.036	9671.038	9671.034	9671.036	9671.038	35
	Upgrade kit for front panels IP 2X	IP 43	1 set	9671.044	9671.046	9671.048	9671.044	9671.046	9671.048
Partial doors for clearance height with front trim panel 100/100 mm		1	9671.150	9671.170	9671.190	9671.150	9671.170	9671.190	37
5 Front trim panels, top 300 mm/ bottom 100 mm for protection category	IP 54	1 set	9672.014	9672.016	9672.018	9672.014	9672.016	9672.018	36
	IP 2X	1 set	9672.034	9672.036	9672.038	9672.034	9672.036	9672.038	36
Front trim panels, top 100 mm/ bottom 300 mm for protection category	IP 54	1 set	9672.024	9672.026	9672.028	9672.024	9672.026	9672.028	36
	IP 2X	1 set	9672.044	9672.046	9672.048	9672.044	9672.046	9672.048	36
Upgrade kit for front trim panels 300/100 mm IP 2X	IP 43	1 set	9672.054	9672.056	9672.058	9672.054	9672.056	9672.058	36
Partial doors for clearance height with front trim panel 300/100 mm		1	9671.158	9671.178	9671.198	9671.158	9671.178	9671.198	37
Partial doors for modular configuration		1	■	■	■	■	■	■	37
Angular baying brackets		4	8800.430						35
Baying connectors, external		6	8800.490						35

Accessories	
Enclosure configuration	33 – 39
Compartment configuration	42 – 51
ISV components	52 – 87

¹⁾ Pack sufficient for 1 pack of side panels.

Form 2-4 enclosures

SV-TS 8 cable chamber enclosures (height 1800 mm)

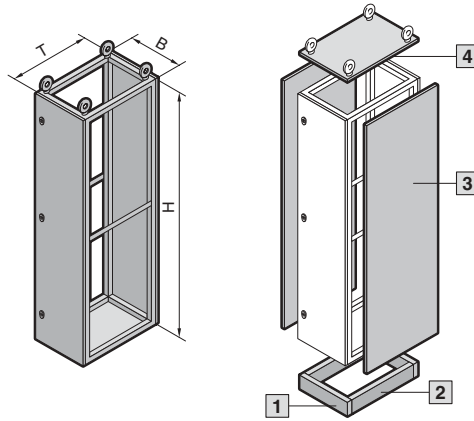

Enclosure frame for the management of incoming and outgoing cables. The use of a roof plate with cable gland plates additionally allows cables to be fed in from above.

Material:

Sheet steel
Enclosure frame, rear panel and gland plates: 1.5 mm
Door: 2.0 mm

Surface finish:

Enclosure frame:
Dipcoat-primed
Door and rear panel:
Dipcoat-primed,
powder-coated in textured
RAL 7035 on the outside
Gland plates: Zinc-plated

Protection category:

Up to IP 54,
depending on the roof plate and
the side panel.

Supply includes:

Enclosure frame with door, rear panel and gland plates.



Accessories:

System accessories,
see Cat. 32, page 890.

Inspection:

Type-tested in accordance with
IEC 60 439-1.

Detailed drawings,

see page 105.

Technical information,

see page 107 – 110.

Width (B) mm	Packs of	300	400	600	Page	
Height (H) mm		1800	1800	1800		
Depth (T) mm		600	600	600		
Model No. SV	1	9670.396	9670.496	9670.696		
Weight (kg)		48.5	52.0	56.0		
Base/plinth						
1 Components front and rear	Height 100 mm	1 set	8601.915	8601.400	8601.600	34
	Height 200 mm	1 set	8602.915	8602.400	8602.600	34
2 Trim panels sides	Height 100 mm	1 set	8601.060	8601.060	8601.060	34
	Height 200 mm	1 set	8602.060	8602.060	8602.060	34
Also required						
3 Side panels for protection category	IP 55	2	8186.235	8186.235	8186.235	33
	IP 2X	2	9671.986	9671.986	9671.986	33
	Upgrade kit for side panels IP 2X	IP 43	2 sets ¹⁾	9671.996	9671.996	9671.996
4 Roof plates for protection category	IP 55	1	9671.636	9671.646	9671.666	38
	IP 43	1	9671.736	9671.746	9671.766	38
	Roof plates for cable entry gland	1	9671.536	9671.546	9665.903	38
Front trim panels, top 300 mm/ bottom 100 mm for protection category	IP 54	1 set	–	9672.014	9672.016	36
	IP 2X	1 set	–	9672.034	9672.036	36
Front trim panels, top 100 mm/ bottom 300 mm for protection category	IP 54	1 set	–	9672.024	9672.026	36
	IP 2X	1 set	–	9672.044	9672.046	36
Upgrade kit for front trim panels 300/100 mm IP 2X	IP 43	1 set	–	9672.055	9672.056	36
Partial doors for clearance height with front trim panel 300/100 mm	1	–	–	–	–	37
Angular baying brackets	4	–	–	8800.430	–	35
Baying connectors, external	6	–	–	8800.490	–	35
Accessories						
Enclosure configuration					33 – 39	
Compartment configuration					42 – 51	
ISV components					52 – 87	
Lock systems						
Standard double-bit lock may be exchanged for a lock with security cylinder/T handles, see page 37.						

¹⁾ Pack sufficient for 1 pack of side panels.

Form 2-4 enclosures

SV-TS 8 cable chamber enclosures (height 2000 mm)

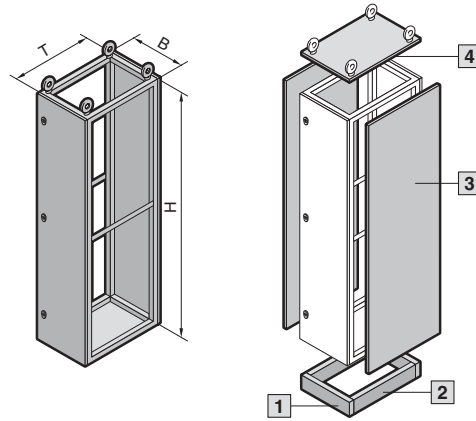

Enclosure frame for the management of incoming and outgoing cables. The use of a roof plate with cable gland plates additionally allows cables to be fed in from above.

Material:

Sheet steel
Enclosure frame, rear panel and gland plates: 1.5 mm
Door: 2.0 mm

Surface finish:

Enclosure frame:
Dipcoat-primed
Door and rear panel:
Dipcoat-primed,
powder-coated in textured
RAL 7035 on the outside
Gland plates: Zinc-plated

Protection category:

Up to IP 54,
depending on the roof plate and
the side panel.

Supply includes:

Enclosure frame with door, rear panel and gland plates.



Accessories:

System accessories,
see Cat. 32, page 890.

Inspection:

Type-tested in accordance with
IEC 60 439-1.

Detailed drawings,
see page 105.

Technical information,
see page 107 – 110.

Width (B) mm	Packs of	300	400	600	300	400	600	Page
Height (H) mm		2000	2000	2000	2000	2000	2000	
Depth (T) mm		600	600	600	800	800	800	
Model No. SV	1	9670.316	9670.416	9670.616	9670.318	9670.418	9670.618	
Weight (kg)		51.5	54.0	59.0	54.0	57.0	62.0	

Base/plinth									
1 Components front and rear	Height 100 mm	1 set	8601.915	8601.400	8601.600	8601.915	8601.400	8601.600	34
	Height 200 mm	1 set	8602.915	8602.400	8602.600	8602.915	8602.400	8602.600	34
2 Trim panels sides	Height 100 mm	1 set	8601.060	8601.060	8601.060	8601.080	8601.080	8601.080	34
	Height 200 mm	1 set	8602.060	8602.060	8602.060	8602.080	8602.080	8602.080	34
Also required									
3 Side panels for protection category	IP 55	2	8106.235	8106.235	8106.235	8108.235	8108.235	8108.235	33
	IP 2X	2	9671.906	9671.906	9671.906	9671.908	9671.908	9671.908	33
	Upgrade kit for side panels IP 2X	IP 43	2 sets ¹⁾	9671.996	9671.996	9671.996	9671.998	9671.998	33
4 Roof plates for protection category	IP 55	1	9671.636	9671.646	9671.666	9671.638	9671.648	9671.668	38
	IP 43	1	9671.736	9671.746	9671.766	9671.738	9671.748	9671.768	38
Roof plates for cable entry gland		1	9671.536	9671.546	9665.903	9671.538	9671.548	9671.568	38
Front trim panels, top 300 mm/ bottom 100 mm for protection category	IP 54	1 set	9672.013	9672.014	9672.016	9672.013	9672.014	9672.016	36
	IP 2X	1 set	9672.033	9672.034	9672.036	9672.033	9672.034	9672.036	36
Front trim panels, top 100 mm/ bottom 300 mm for protection category	IP 54	1 set	9672.023	9672.024	9672.026	9672.023	9672.024	9672.026	36
	IP 2X	1 set	9672.043	9672.044	9672.046	9672.043	9672.044	9672.046	36
Upgrade kit for front trim panels 300/100 mm IP 2X	IP 43	1 set	9672.053	9672.054	9672.056	9672.053	9672.054	9672.056	36
Partial doors for clearance height with front trim panel 300/100 mm		1	9671.126	9671.156	9671.176	9671.126	9671.156	9671.176	37
Angular baying brackets		4	8800.430						35
Baying connectors, external		6	8800.490						35

Accessories	
Enclosure configuration	33 – 39
Compartment configuration	42 – 51
ISV components	52 – 87

Lock systems
Standard double-bit lock may be exchanged for a lock with security cylinder/T handles, see page 37.

¹⁾ Pack sufficient for 1 pack of side panels.

Form 2-4 enclosures

SV-TS 8 cable chamber enclosures (height 2200 mm)

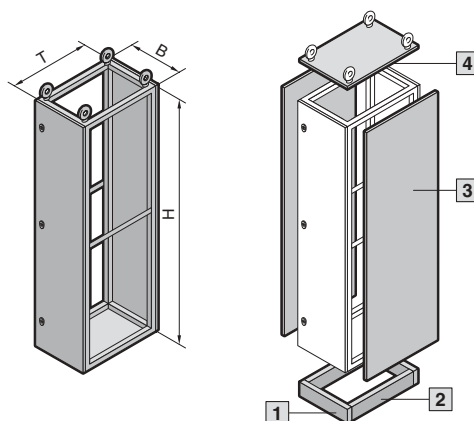

Enclosure frame for the management of incoming and outgoing cables. By selecting a roof plate with cable gland plates, the cables and conductors may additionally be fed in from above.

Material:

Sheet steel
Enclosure frame, rear panel and gland plates: 1.5 mm
Door: 2.0 mm

Surface finish:

Enclosure frame:
Dipcoat-primed
Door and rear panel:
Dipcoat-primed,
powder-coated in textured RAL 7035 on the outside
Gland plates: Zinc-plated

Protection category:

Up to IP 54,
depending on the roof plate and the side panel.

Supply includes:

Enclosure frame with door, rear panel and gland plates.



Accessories:

System accessories,
see Cat. 32, page 890.

Inspection:

Type-tested in accordance with IEC 60 439-1.

Detailed drawings,

see page 105.

Technical information,

see page 107 – 110.

Width (B) mm	Packs of	300	400	600	300	400	600	Page
Height (H) mm		2200	2200	2200	2200	2200	2200	
Depth (T) mm		600	600	600	800	800	800	
Model No. SV	1	9670.336	9670.436	9670.636	9670.338	9670.438	9670.638	
Weight (kg)		54.0	56.5	61.0	58.0	61.0	65.0	

Base/plinth

1 Components front and rear	Height 100 mm	1 set	8601.915	8601.400	8601.600	8601.915	8601.400	8601.600	34
	Height 200 mm	1 set	8602.915	8602.400	8602.600	8602.915	8602.400	8602.600	34
2 Trim panels sides	Height 100 mm	1 set	8601.060	8601.060	8601.060	8601.080	8601.080	8601.080	34
	Height 200 mm	1 set	8602.060	8602.060	8602.060	8602.080	8602.080	8602.080	34

Also required

3 Side panels for protection category	IP 55	2	8126.235	8126.235	8126.235	8128.235	8128.235	8128.235	33
	IP 2X	2	9671.926	9671.926	9671.926	9671.928	9671.928	9671.928	33
Upgrade kit for side panels IP 2X	IP 43	2 sets ¹⁾	9671.996	9671.996	9671.996	9671.998	9671.998	9671.998	33
4 Roof plates for protection category	IP 55	1	9671.636	9671.646	9671.666	9671.638	9671.648	9671.668	38
	IP 43	1	9671.736	9671.746	9671.766	9671.738	9671.748	9671.768	38
Roof plates for cable entry gland		1	9671.536	9671.546	9665.903	9671.538	9671.548	9671.568	38
Front trim panels, top 300 mm/ bottom 100 mm for protection category	IP 54	1 set	9672.013	9672.014	9672.016	9672.013	9672.014	9672.016	36
	IP 2X	1 set	9672.033	9672.034	9672.036	9672.033	9672.034	9672.036	36
Front trim panels, top 100 mm/ bottom 300 mm for protection category	IP 54	1 set	9672.023	9672.024	9672.026	9672.023	9672.024	9672.026	36
	IP 2X	1 set	9672.043	9672.044	9672.046	9672.043	9672.044	9672.046	36
Upgrade kit for front trim panels 300/100 mm IP 2X	IP 43	1 set	9672.053	9672.054	9672.056	9672.053	9672.054	9672.056	36
Partial doors for clearance height with front trim panel 300/100 mm		1	9671.128	9671.158	9671.178	9671.128	9671.158	9671.178	37
Angular baying brackets		4	8800.430						35
Baying connectors, external		6	8800.490						35

Accessories

Enclosure configuration	33 – 39
Compartment configuration	42 – 51
ISV components	52 – 87

Lock systems

Standard double-bit lock may be exchanged for a lock with security cylinder/T handles, see page 37.

¹⁾Pack sufficient for 1 pack of side panels.

Form 2-4 enclosures

SV-TS 8 busbar enclosures (width 200 mm)

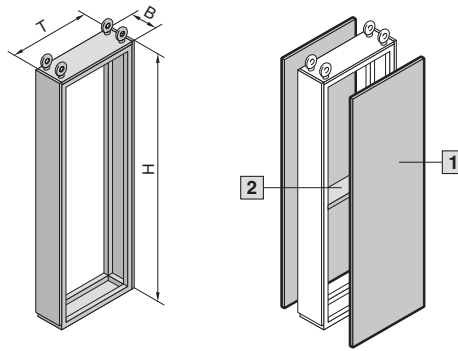

Empty enclosure for baying to TS 8 enclosures, to accommodate vertical busbar systems.

Material:

Sheet steel enclosure frame with front trim panel, rear panel and firmly linked roof and base plate: 1.5 mm

Surface finish:

Enclosure frame, gland plate, roof plate: Dipcoat-primed and powder-coated in textured RAL 7035
Rear panel, front trim panel: Dipcoat-primed and powder-coated in textured RAL 7035

Protection category:
Up to IP 55

Supply includes:

Enclosure frame with front trim panel, rear panel, roof and gland plate.

+ **Accessories:**

System accessories, see Cat. 32, page 890.

Inspection:

Type-tested in accordance with IEC 60 439-1.

Detailed drawings, see page 106.

Technical information, see page 107 – 110.

Width (B) mm	Packs of	200	200	200	200	Page
Height (H) mm		2000	2200	2000	2200	
Depth (T) mm		600	600	800	800	
Model No. SV	1	9670.206	9670.226	9670.208	9670.228	
Weight (kg)		31.5	35	33.5	37	

Base/plinth²⁾

Also required

1	Side panels for protection category IP 55	2	8106.235	8126.235	8108.235	8128.235	33
	IP 2X	2	9671.906	9671.926	9671.908	9671.928	33
	Upgrade kit for side panels IP 2X IP 43	2 sets ¹⁾	9671.996	9671.996	9671.998	9671.998	33
2	Coupling set mounting kit	1 set	9674.196	9674.196	9674.198	9674.198	94
	Angular baying brackets	4			8800.430		35
	Baying connectors, external	6			8800.490		35

Accessories

Compartment configuration	42 – 51
ISV components	52 – 87

¹⁾ Pack sufficient for 1 pack of side panels.

²⁾ The busbar enclosure is on one base/plinth together with the main enclosure, i.e. please select a base/plinth for the main enclosure which is 200 mm wider.

SV-TS 8 modular enclosure

SV-TS 8 cable chamber enclosure

Accessory components for external mounting on a modular or cable chamber enclosure. The required components should be selected depending on the required function.

We highly recommend the software Rittal Power Engineering for easier selection – see Cat. 32, page 1153.

Accessory components	Page
1 Side panels	33
2 Front trim panels	35
3 Roof frame bars/cross members	36
4 Roof plates	38
5 Cable entry glands	39

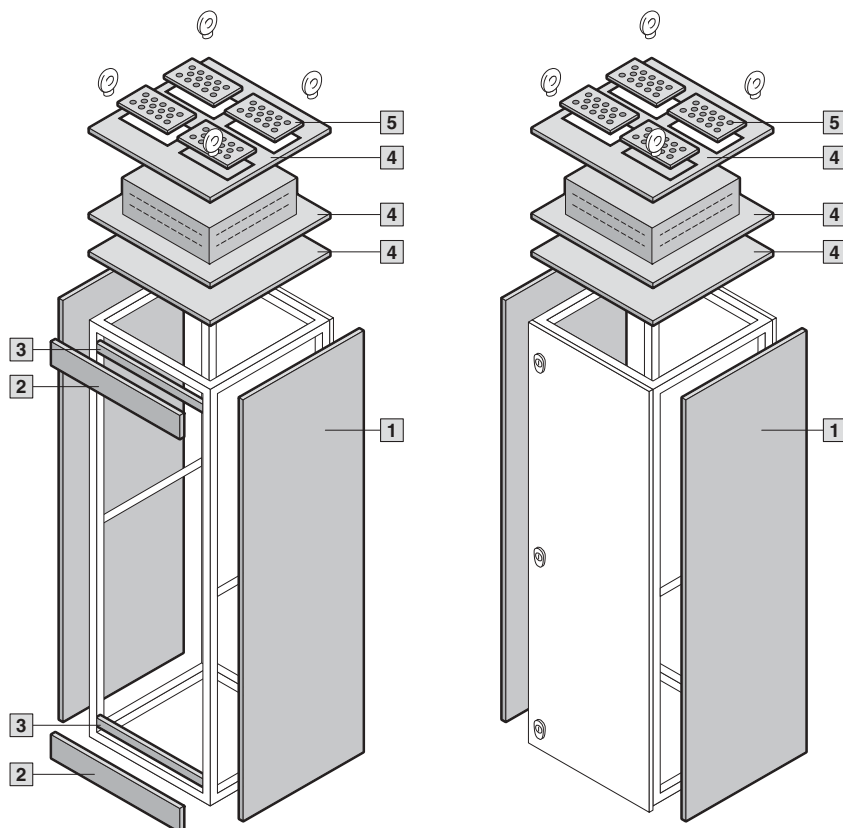

Side panels

for TS

Simple positioning on the frame, thanks to the location aid.

Six enclosure panel fasteners with earthing insert ensure automatic potential equalisation with superior EMC protection. Earthing bolts with contact surface are integrated.

Material:

Sheet steel, 1.5 mm

Surface finish:

Textured RAL 7035

Supply includes:

Assembly parts.



For enclosures		Version	Packs of	Model No. SV
Height mm	Depth mm			
1800	600	IP 55 sealed	2	8186.235
2000	600		2	8106.235
2200	600		2	8126.235
2000	800		2	8108.235
2200	800		2	8128.235
1800	600	IP 2X with ventilation hole	2	9671.986
2000	600		2	9671.906
2200	600		2	9671.926
2000	800		2	9671.908
2200	800		2	9671.928

+ Accessories:

Upgrade kit IP 43

–	600	for side panels IP 2X	2 sets	9671.996¹⁾
–	800		2 sets	9671.998¹⁾

¹⁾ Pack sufficient for 1 pack of side panels.

Form 2-4 enclosure system accessories

Enclosure configuration



Base/plinth components front and rear

Sheet steel for TS, CM, TP, PC-TS, IW, FR(i), TE

Base/plinth component consisting of one trim panel and two pre-configured corner pieces. In 200 mm high base/plinth components, one trim panel is divided into two for cable entry.

Material:

Sheet steel, spray-finished
Cover caps plastic RAL 9005/7035

Supply includes:

1 set =
2 base/plinth components, 4 cover caps,
4 screws and captive nuts M12
for mounting on the enclosure.

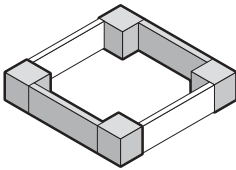

+ Accessories:

Base mounting plate SO 2817.000,
see Cat. 32, page 896.
Filter mat for vented variants,
see Cat. 32, page 898.

Detailed drawing,
see Cat. 32, page 894.

German patent no. 198 60 408

For enclosure width mm	Version	Colour		Model No. TS	
		RAL 7022	RAL 7035	100 mm high	200 mm high
300	Solid	–	■	8601.905	8602.905
	Solid	■	–	8601.915	8602.915
400	Solid	■	–	8601.400	8602.400
500	Solid	■	–	8601.500	8602.500
600	Solid	■	–	8601.600	8602.600
	Solid	–	■	8601.605¹⁾	8602.605
	Vented	–	■	7825.601²⁾	–
800	Vented with designer cover	–	■	7825.603	–
	Solid	■	–	8601.800	8602.800
	Solid	–	■	8601.805³⁾	8602.805
	Vented	–	■	7825.801⁴⁾	–
850	Vented with designer cover	–	■	7825.803	–
	Solid	■	–	8601.850	8602.850
1000	Solid	■	–	8601.000	8602.000
1100	Solid	■	–	8601.300	8602.100
1200	Solid	■	–	8601.200	8602.200
1600	Solid	■	–	8601.920	8602.920

¹⁾ Variant in RAL 9005: TS 8601.602
²⁾ Variant in RAL 9005: DK 7825.605

³⁾ Variant in RAL 9005: TS 8601.802
⁴⁾ Variant in RAL 9005: DK 7825.805



Base/plinth trim, side

Sheet steel for TS, CM, TP, PC-TS, IW, FR(i), TE

For mounting between the base/plinth components. At 200 mm height, two 100 mm base/plinth trims may be used. Base/plinth trim (100 mm high) may be installed rotated through 90° in order to stabilise bayed base/plinth components.

Material:

Sheet steel, spray-finished

Supply includes:

1 set =
2 base/plinth trim panels, including parts for
attaching to the base/plinth components.

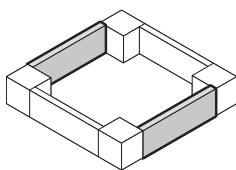

! Also required:

Base/plinth baying brackets TS 8601.100,
see Cat. 32, page 896,
when mounting base/plinth trim panels rotated
through 90°.

+ Accessories:

Assembly bolts for base/plinth,
see Cat. 32, page 896.

Detailed drawing,
see Cat. 32, page 894.

For enclosure depth mm	Colour		Model No. TS	
	RAL 7022	RAL 7035	100 mm high	200 mm high
300	■	–	8601.030	8602.030
400	■	–	8601.040	8602.040
500	■	–	8601.050	8602.050
600	■	–	8601.060	8602.060
	–	■	8601.065	8602.065
800	■	–	8601.080	8602.080
	–	■	8601.085¹⁾	8602.085
900	–	■	8601.095²⁾	8602.095
1000	–	■	8601.015³⁾	8602.015
1200	–	■	8601.025⁴⁾	8602.025

¹⁾ Variant in RAL 9005: TS 8601.086
²⁾ Variant in RAL 9005: TS 8601.092

³⁾ Variant in RAL 9005: TS 8601.010
⁴⁾ Variant in RAL 9005: TS 8601.026

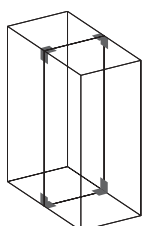

Angular baying bracket for TS/TS

The robust connection when transporting bayed enclosure suites.

Screw-fastening either

- Horizontally and vertically with 8 screws
 - Horizontally with 2 screws and M8 threaded blocks, vertically with 4 screws
- is supported.

Material:

Sheet steel, zinc-plated, passivated

Supply includes:

Assembly parts.

Packs of	Model No. TS
4	8800.430



Baying connector, external for TS/TS

For mounting on the vertical enclosure sections.

Simply position on the outside and screw-fasten either from the inside or outside.

Material:

Sheet steel, zinc-plated, passivated or stainless steel 1.4301 (AISI 304)

Supply includes:

Assembly parts.

Version	Packs of	Model No. TS
Sheet steel	6	8800.490
Stainless steel	6	8700.000

German patent no. 197 37 668

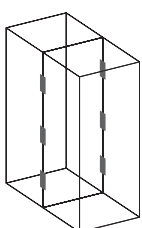

Front trim panels for TS

Required as an upper and lower height filler when partial doors are used.
Height: 100 mm.

Material:

Sheet steel, 2 mm

Surface finish:

Textured RAL 7035

Supply includes:

2 front trim panels, including assembly parts.

! Also required:

Cross member, see page 36.



Version	Packs of	Model No. SV			
		For enclosure width			
		300 mm	400 mm	600 mm	800 mm
IP 54 sealed	1 set	9671.013	9671.014	9671.016	9671.018
IP 2X with ventilation hole	1 set	9671.033	9671.034	9671.036	9671.038
Accessories					
Upgrade kit IP 43 for front trim panel IP 2X	1 set	9671.043	9671.044	9671.046	9671.048

Form 2-4 enclosure system accessories

Enclosure configuration



Front trim panels

for TS (busbar compartment)

Required to conceal a 300 mm high busbar compartment and for using partial doors as an upper and lower height filler.

Height of busbar compartment cover: 300 mm.
Height of front trim panel opposite: 100 mm.

Material:

Sheet steel, 2 mm

Colour:

Textured RAL 7035

Supply includes:

2 front trim panels, including assembly parts.



Also required:

Roof frame bars, see page 38.
Cross members, see page 36.



Accessories:

Upgrade kit IP 43

for front trim panels IP 2X

For enclosure width mm	Version	Packs of	Model No. SV
300	IP 2X with ventilation hole	1 set	9672.053
400		1 set	9672.054
600		1 set	9672.056
800		1 set	9672.058
1000		1 set	9672.050¹⁾
1200		1 set	9672.052¹⁾

¹⁾ Delivery times available on request.

For enclosure width mm	Height of front trim panels		Packs of	Model No. SV	
	top mm	bottom mm		Version	
				IP 54 sealed	IP 2X with ventilation hole
300	300	100	1 set	9672.013	9672.033
300	100	300	1 set	9672.023	9672.043
400	300	100	1 set	9672.014	9672.034
400	100	300	1 set	9672.024	9672.044
600	300	100	1 set	9672.016	9672.036
600	100	300	1 set	9672.026	9672.046
800	300	100	1 set	9672.018	9672.038
800	100	300	1 set	9672.028	9672.048
1000	300	100	1 set	9672.010¹⁾	9672.030¹⁾
1000	100	300	1 set	9672.020¹⁾	9672.040¹⁾
1200	300	100	1 set	9672.012¹⁾	9672.032¹⁾
1200	100	300	1 set	9672.022¹⁾	9672.042¹⁾

¹⁾ Delivery times available on request.



Cross members

for TS

For use as sealing member between:

- Front trim panels
- Trim panels
- Partial doors

Material:

Sheet steel, 1 mm

Colour:

RAL 7035

Supply includes:

Assembly parts and sealing material.



For enclosure width mm	Packs of	Model No. SV
300	5	9671.003
400	5	9671.004
600	5	9671.006
800	5	9671.008

Form 2-4 enclosure system accessories

Enclosure configuration



Partial doors

for TS, without lock

Door hinges with non-drilled internal fastening.
Door may be optionally hinged on the right or left.

Material:

Sheet steel, 2 mm

Surface finish:

Textured RAL 7035

Supply includes:

Hinges and assembly parts.



Also required:

Locks,
see page 37.
Cross members,
see page 36.



Height mm	No. of locks required	Packs of	Model No. SV			
			For enclosure width			
			300 mm	400 mm	600 mm	800 mm
150	1	1	–	9671.141	9671.161	9671.181
200	1	1	–	9671.142	9671.162	9671.182
250	1	1	–	9671.147	9671.167	9671.187
300	1	1	–	9671.143	9671.163	9671.183
400	1	1	–	9671.144	9671.164	9671.184
600	2	1	–	9671.146	9671.166	9671.186
800	2	1	–	9671.148	9671.168	9671.188
1000	3	1	–	9671.140	9671.160	9671.180
1600	3	1	9671.126	9671.156	9671.176	9671.196
1800	3	1	9671.128	9671.158	9671.178	9671.198
2000	3	1	9671.120	9671.150	9671.170	9671.190

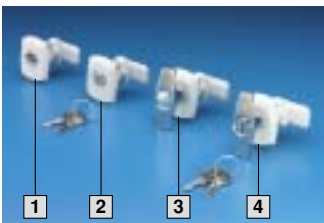

Locks

For installation in partial doors or in exchange for AE cam locks.

Material:

Housing made of fibreglass-reinforced plastic,
bolt made of PA

Colour:

RAL 7035

Supply includes:

Housing, lock insert, bolt including assembly parts.

Version	Packs of	Model No. SV
1 With double-bit insert	1	9671.130
2 With cylinder insert, lock no. 3524 E	1	9671.132
3 With T handle	1	9671.134
4 With T handle and lock insert, lock no. 3524 E	1	9671.135
5 Fastener lug with end stop ¹⁾	2	9671.138

¹⁾ Must be used if the twist lock cannot be locked on the TS 8 frame.



5



Form 2-4 enclosure system accessories

Enclosure configuration



Roof frame bars, horizontal for TS

Required as sealing bar between 300 mm high front trim panels and partial doors.

Material:
Sheet steel, 1.5 mm

Colour:
RAL 7035

Supply includes:
Assembly parts and sealing material.

For enclosure width mm	Width mm	Packs of	Model No. SV
300	208	2	9672.003
400	308	2	9672.004
600	508	2	9672.006
800	708	2	9672.008
1000	908	2	9672.000¹⁾
1200	1108	2	9672.002¹⁾

¹⁾ Delivery times available on request.



Roof plates for TS

For SV-TS 8 modular and cable chamber enclosures without roof plate and in exchange for the standard roof plate for other TS enclosures.

Material:
Sheet steel, 1.5 mm

Surface finish:
Textured RAL 7035

Supply includes:
Assembly parts.



Also required:

Cable entry gland, see page 39.

No. of cable entry glands required	
For roof plate	Quantity required
SV 9671.536	2
SV 9671.546	3
SV 9665.903	4
SV 9671.586	8
SV 9671.538	2
SV 9671.548	4
SV 9671.568	8
SV 9671.588	8



For enclosures			Model No. SV				
Width mm	Depth mm	Packs of	Version				
			IP 55 sealed	IP 43 with ventilation hole	IP 2X with ventilation hole	For cable entry gland	With pressure relief valve
300	600	1	9671.636	9671.736	–	9671.536	–
400	600	1	9671.646	9671.746	–	9671.546	9671.446¹⁾
600	600	1	9671.666	9671.766	9660.235	9665.903	9660.935¹⁾
800	600	1	9671.686	9671.786	9660.245	9671.586	9660.945¹⁾
300	800	1	9671.638	9671.738	–	9671.538	–
400	800	1	9671.648	9671.748	–	9671.548	9671.448¹⁾
600	800	1	9671.668	9671.768	9659.525	9671.568	9671.468¹⁾
800	800	1	9671.688	9671.788	9659.535	9671.588	9671.488¹⁾
Build height mm			0	93	72	0 ²⁾	25

¹⁾ Delivery times available on request.

²⁾ Build height depending on the cable entry gland.

Form 2-4 enclosure system accessories

Enclosure configuration

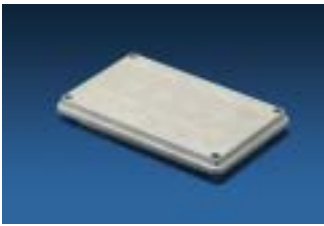

1

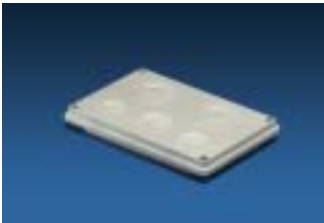

2



3

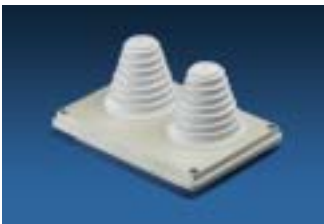

4

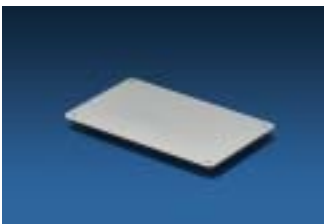

5

Cable entry glands

- Including seal
- External dimensions 250 x 160 mm
- Protection category IP 55

Material:

SV 9665.750 to 9665.780

Insulating material RAL 7032

SV 9665.785

Sheet steel, spray-finished in RAL 7035

Version	Packs of	Model No. SV
1 14 x M25/32	1	9665.750
2 2 x M25/32/40, 1 x M32/40/50, 2 x M40/50/63	1	9665.760
3 With sealing membranes 32 x dia. 7 – 16 mm, 4 x dia. 10 – 20 mm, 3 x dia. 14 – 26 mm	1	9665.770
4 With entry glands up to 66 mm diameter	1	9665.780
5 Solid	4	9665.785

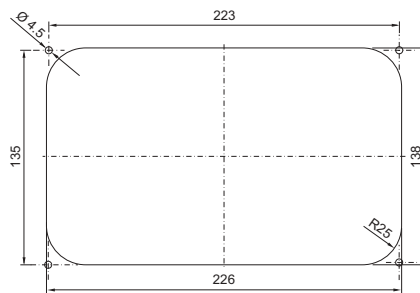

Cut-out dimensions for
SV 9665.750 to SV 9665.785



PS punched rails 23 x 23 mm

For installing a vertical RiLine60 multi-terminal busbar system on the vertical enclosure section, see Cat. 32, page 998.



Fastening bracket

For mounting the PS mounting rail on the TS frame, see Cat. 32, page 1006.

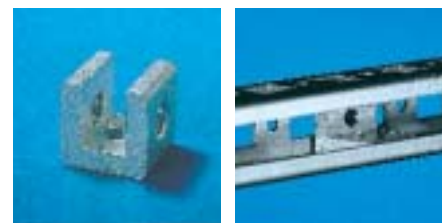

U nuts

For fastening the PS mounting rail on the bracket and fastening the busbar support to the PS mounting rail, see Cat. 32, page 1010.



Perfection down to the smallest detail

Time-saving system assembly, form-separated interior installation, innovative module components, and an extensive range of accessories. Rittal Ri4Power Form 2-4 is a modular system for the time-optimised configuration of form-separated low-voltage switchgear. Fresh approaches in installation technology and multifunctional components now make it possible to install the internal compartmentalisation of a low-voltage switchgear with just a few operations. The TS 8 Top enclosure system, as the system platform for Ri4Power Form 2-4, provides infinite possibilities, offering the ideal solution to suit your requirements, however specific.

Side panel modules



The side panel modules form the basic component for the internal installation.



One-person assembly: Locate components into the TS 8 pitch pattern, and release. Both hands are now free for the next installation step.



The **modular installation concept** enables optimum utilisation of the assembly area, thanks to compartment heights in small increments (150, 200, 250 mm, etc.).



The **tried-and-trusted TS 8 pitch pattern** is used for many Ri4Power components, enabling use of the TS 8 system accessories.

Partial doors and cross members



Simple assembly and high quality standards characterise the new partial door system.



The **support strip** is located into the TS 8 pitch pattern in accordance with the one-person principle.



Fitting accuracy and precision are prerequisites for modular technology.



The **hinge** of the partial doors is mounted on the TS 8 frame **without any holes needing to be drilled.**

Mini-TS



Mini-TS profile – the TS pitch in the smallest dimension. An extension of the assembly spectrum for small and medium loads.



The **three assembly sides of the Mini-TS profile** ensure the diversity and fast assembly technology of the TS 8 enclosure profile at all times, whatever the location.



The **connector pieces** always provide an attachment point at every position in the 25 mm pitch, irrespective of the mounting bracket type.



The **small size** means the Mini-TS bars can be mounted without conflict in the internal and external mounting level of the TS 8 enclosure.

Form 2-4 compartment

Compartment configuration

Modular outgoing panel with distributor bar system

Inside the compartment

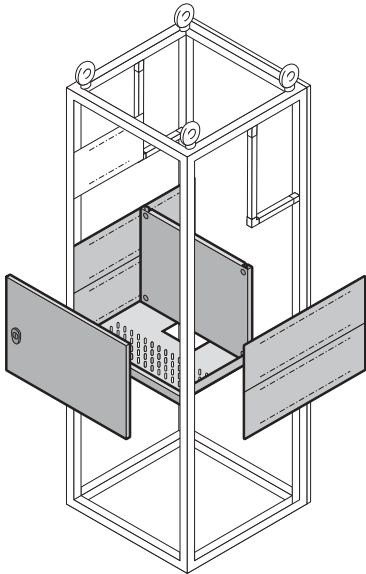

Behind the compartment

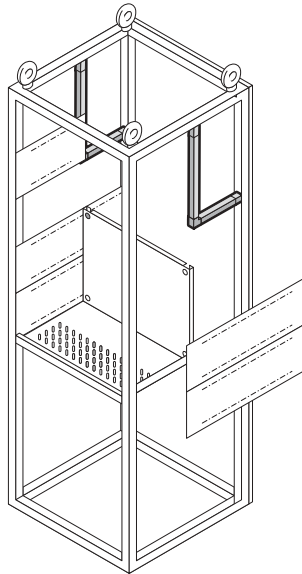

Compartment layout

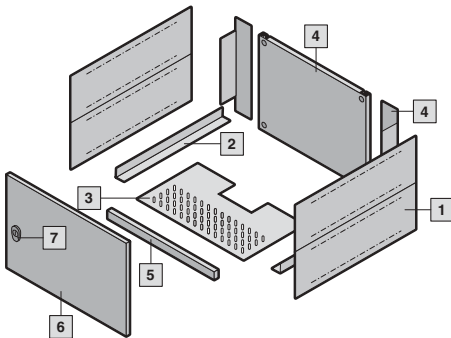

Busbar space separation (only required with main busbar systems in the rear area)

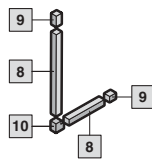

Cable chamber

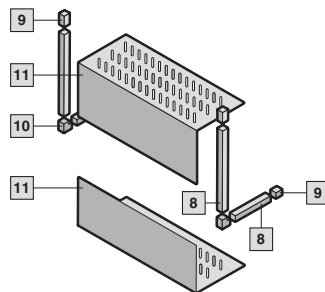
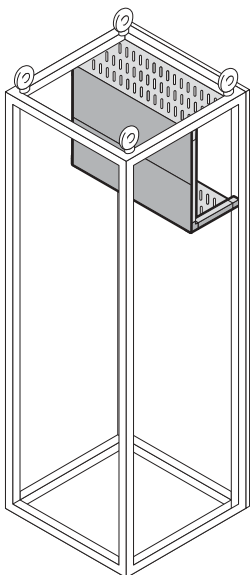

Power circuit-breaker panel

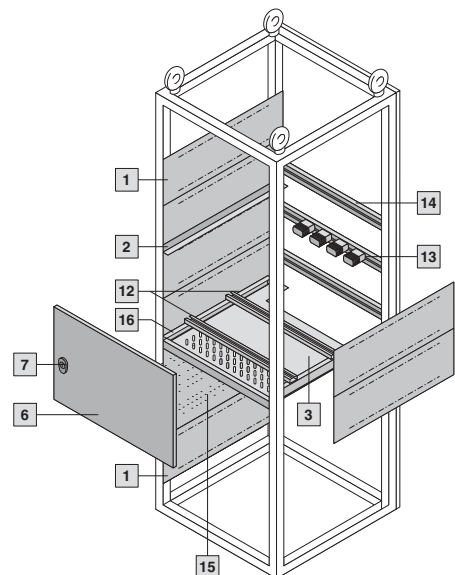

Accessory components for the configuration of modular or cable chamber enclosures. The required components are selected depending on the required functional spaces and system configuration.

For an explanation of the selection, we highly recommend the software Rittal Power Engineering – see Cat. 32, page 1153.

Accessory components	Page
1 Functional space side panel modules	43
2 Mounting bracket for functional space divider	45
3 Functional space divider	46
4 Partial mounting plates including angle brackets	48
5 Cross members	36
6 Partial doors	37
7 Locks	37
8 Mini-TS profiles 17 x 15.5 mm	49
9 Frame connector piece (external mounting level)	50
10 Corner connector	50
11 Cover plates	44
12 Power circuit-breaker support bar	46
13 Stacking insulator	51
14 Support bar for packing insulator	51
15 Functional space side panel modules for cable connection space	43
16 Mounting bracket for functional space divider and power circuit-breaker support bar	45
Connection space covers	44
Support frame	49

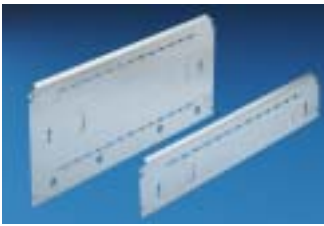

Compartment side panel modules

for TS

For internal separation as a side divider panel for compartments, for mounting in the TS pitch pattern. Prepared for the attachment of mounting brackets for horizontal functional space dividers or mounting plates with two M40 knockouts for cable entry. Two TS system punchings allow the use of additional TS accessories.

The side panel modules for reduced compartment depth and an auxiliary construction using the Mini-TS profiles can be used to provide a separate enclosure space in the side panel area, e.g. for the provision of a busbar system. Version with plastic plate has prepunched knockouts for cable entry.



Material:

Sheet steel, zinc-plated, passivated, 1.5 mm

Supply includes:

Assembly parts.



Accessories:

Mini-TS extrusions and connector pieces, see page 49, 50.

Gland plates, see page 43.

Height mm	Version with plastic gland plate	Packs of	Model No. SV		
			For compartment depth		
			425 mm	600 mm	800 mm
100	–	6	9673.051	9673.061	9673.081
150	–	6	9673.055	9673.065	9673.085
150	■	6	9673.155	9673.165	9673.185
200	–	6	9673.052	9673.062	9673.082
200	■	6	9673.152	9673.162	9673.182
600	–	2	–	9673.066	9673.086
600	■	2	–	9673.166	9673.186



Gland plates

To seal additional cable entries.

Material:

PVC, 3 mm
fire protection corresponding to UL 94-V0

Colour:

RAL 7004

Supply includes:

Assembly parts.

For side panel modules Height mm	Packs of	Model No. SV
200/600	10	9673.192



Functional space side panel modules

for TS (cable connection space)

For mounting a Maxi-PLS cable connection bar system in a TS enclosure.

Material:

Sheet steel, zinc-plated, passivated, 2 mm

Supply includes:

Assembly parts.

Height mm	Packs of	Model No. SV	
		For enclosure depth	
		600 mm	800 mm
450	2	9673.069	9673.089
Suitable for infeeds			
Maxi-PLS	Number of poles		
1600/2000	3-pole	■	■
1600/2000	4-pole	■	■
3200	3-pole	■	■
3200	4-pole	–	■



Also required:

2 functional space side panel modules with height 150 mm, see page 43.
End support, see page 74/76.

Form 2-4 compartment

Compartment configuration



Connection space covers

For retrospective shielding of a Maxi-PLS cable connection bar system with punched section without mounting flange in a form-separated enclosure.

Material:

Sheet steel, zinc-plated, passivated, 1.5 mm

Supply includes:

Assembly parts.

Height mm	Packs of	Model No. SV	
		For enclosure depth	
		600 mm	800 mm
790,5	2	9673.060	9673.080



Also required:

Functional space side panel modules, see page 43.



Cover plates

for rear busbar system in the cable chamber

To separate an area of the cable chamber enclosure for a rear-mounted busbar system. Attachment requires an auxiliary construction made from Mini-TS sections, to which the cover plates are attached and fastened.

Material:

Sheet steel, zinc-plated, passivated, 1.5 mm

Supply includes:

Assembly parts.



Also required:

Frame connector piece (4 x SV 9673.901), see page 50.
 Corner connector (2 x SV 9673.902), see page 50.
 Mini-TS extrusions for SV 9673.5X0 (2 x SV 9673.915, 2 x SV 9673.953), see page 49.
 Mini-TS extrusions for SV 9673.5X2 (2 x SV 9673.920, 2 x SV 9673.983), see page 49.



For enclosure depth mm	For enclosure width mm	Width mm	Height mm	Depth mm	Packs of	Model No. SV
600	300	297	540	170.5	2 sets	9673.530¹⁾
600	400	397	540	170.5	2 sets	9673.540¹⁾
600	600	597	540	170.5	2 sets	9673.560¹⁾
600/800	300	297	837	245.5	1 set	9673.532²⁾
600/800	400	397	837	245.5	1 set	9673.542²⁾
600/800	600	597	837	245.5	1 set	9673.562²⁾

¹⁾ Suitable for RiLine60 and Maxi-PLS 1600/2000

²⁾ Suitable for RiLine60, Maxi-PLS 1600/2000/3200 and Flat-PLS



Mounting bracket for functional space divider

The mounting bracket is fastened to the TS frame or between a frame section and an auxiliary construction.

It is suitable both for fastening to a side panel module and also directly to the TS frame. The functional space dividers can be inserted into the installation openings provided.

Material:

Sheet steel, zinc-plated, passivated, 1.5 mm

Supply includes:

Assembly parts.



For compartment depth mm	Length mm	Packs of	Model No. SV
425	427	8	9673.405 ¹⁾
600	552	8	9673.406
800	752	8	9673.408

¹⁾ In conjunction with vertical busbar space separation.



Mounting bracket for functional space divider (inner mounting level)

The mounting bracket is secured to a TS punched section with mounting flange 23 x 73 mm.

The functional space dividers can be inserted into the installation openings provided.

Material:

Sheet steel, zinc-plated, passivated, 1.5 mm

Supply includes:

Assembly parts.



For compartment depth mm	Length mm	Packs of	Model No. SV
600	544.5	8	9673.416
800	744.5	8	9673.418



Also required:

TS punched section with mounting flange, 23 x 73 mm, see Cat. 32, page 995.



Mounting bracket for functional space divider and power circuit-breaker support bar

The mounting bracket is attached to a side panel module. The functional space dividers can be inserted into the installation openings provided. The power circuit-breaker support bar may be attached to the upper level.

Material:

Sheet steel, zinc-plated, passivated, 2 mm

Supply includes:

Assembly parts.



For compartment depth mm	Length mm	Packs of	Model No. SV
600	552	2	9673.426
800	752	2	9673.428



Also required:

Functional space side panel modules, see page 43.
Power circuit-breaker support bar, see page 46

Form 2-4 compartment

Compartment configuration

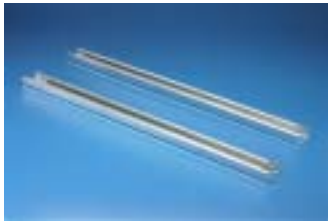

Power circuit-breaker support bar

For the configuration of open power circuit-breakers (ACB) in compartments. The power circuit-breaker support bar is attached to a mounting bracket for functional space dividers and power circuit-breaker support bar.

Material:

Sheet steel, zinc-plated, passivated, 2.5 mm

Supply includes:

Assembly parts.



For enclosure width mm	Length mm	Packs of	Model No. SV
400	351	2	9673.004
600	551	2	9673.006
800	751	2	9673.008



Also required:

Mounting bracket for functional space divider and power circuit-breaker support bar see page 45.
Attachment kit for power circuit-breaker installation, see page 46



Attachment set

for power circuit-breaker installation

For attaching open power circuit-breakers (ACB) to power circuit-breaker support bars.

Material:

Sheet steel, zinc-plated

Supply includes:

4 threaded plates.

Packs of	Model No. SV
1 set	9660.970

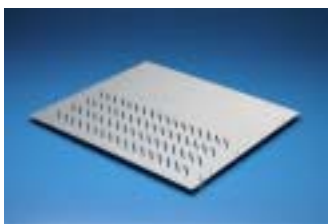

Functional space divider for TS

For the horizontal separation of compartments. In combination with the side panel modules, produces form separation in accordance with Form 3 or 4. Two mounting brackets are required to install the functional space divider.

Material:

Sheet steel, zinc-plated, passivated, 1.25 mm



Also required:

Mounting bracket, see page 45.
Cross members, see page 36.



For enclosure width mm	For compartment depth mm	Width mm	Depth mm	Packs of	Model No. SV	
					Version	
					Vented ¹⁾	Solid ²⁾
400	425	306	445	4	9673.444	9673.440
400	600	306	588	4	9673.445	9673.441
400	800	306	788	4	9673.448	9673.449
600	425	506	445	4	9673.464	9673.460
600	600	506	588	4	9673.465	9673.461
600	800	506	788	4	9673.468	9673.469
800	425	706	445	4	9673.484	9673.480
800	600	706	588	4	9673.485	9673.481
800	800	706	788	4	9673.488	9673.489

¹⁾ With ventilation holes

²⁾ Derating of 5 % with enclosure protection category IP 2X or less, in relation to the rated currents of the selected busbar system.

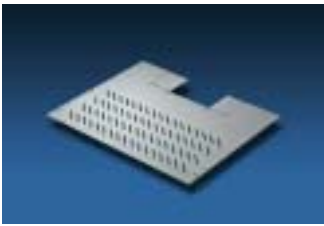

Functional space divider

for TS, prepared for RiLine60 bar systems

For the horizontal separation of compartments with integrated RiLine60 multi-terminal busbar system. In combination with the side panel modules, produces a separation in accordance with Form 3 or 4. Two mounting brackets are required to install the functional space divider.

Material:

Sheet steel, zinc-plated, passivated, 1.25 mm



Also required:

Mounting bracket, see page 45.
Cross members, see page 36.



For enclosure width mm	For compartment depth mm	Width mm	Depth mm	Position of the bar system in the compartment	Packs of	Model No. SV	
						Version	
						Vented ¹⁾	Solid ²⁾
400	401	306	413	–	4	9673.434 ²⁾	9673.430 ²⁾
600	401	506	413	–	4	9673.454	9673.450
800	401	706	413	Right	4	9673.474	9673.470
800	401	706	413	Left	4	9673.475	9673.471

¹⁾ With ventilation holes

²⁾ Only for use with a 3-pole bar system.

³⁾ Derating of 5 % with enclosure protection category IP 2X or less, in relation to the rated currents of the selected busbar system.



Functional space divider

for TS, prepared for the entry of vertical busbar systems

For the horizontal separation of compartments with vertical busbars. In combination with the side panel modules, produces form separation in accordance with Form 3 or 4. Two mounting brackets are required to install the functional space divider.

Material:

Sheet steel, zinc-plated, passivated, 1.25 mm



Also required:

Mounting bracket, see page 45.
Cross members, see page 36.
Gland plate, see page 47.

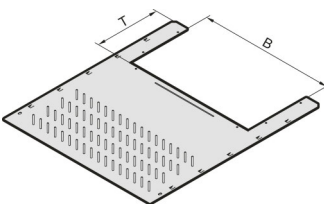

For enclosure width mm	For compartment depth mm	Width mm	Depth mm	Width of entry (B) mm	Depth of entry (T) mm	Packs of	Model No. SV	
							Version	
							Vented ¹⁾	Solid ²⁾
400	600	306	588	212	201	4	9673.436	9673.437
400	800	306	788	212	201	4	9673.438	9673.439
600	600	506	588	412	201	4	9673.456	9673.457
600	800	506	788	412	201	4	9673.458	9673.459
800	600	706	588	612	201	4	9673.476	9673.477
800	800	706	788	612	201	4	9673.478	9673.479

¹⁾ With ventilation holes

²⁾ Derating of 5 % with enclosure protection category IP 2X or less, in relation to the rated currents of the selected busbar system.

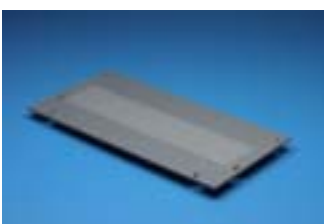

Gland plate

To conceal the cable entry opening.

For enclosure width mm	Width mm	Height mm	Packs of	Model No. SV
400	250	223.5	4	9673.504
600	450	223.5	4	9673.506
800	650	223.5	4	9673.508

Form 2-4 compartment

Compartment configuration



Partial mounting plates

With and without cable entry, for TS

For direct attachment to the functional space side panel modules.

- Universal internal installation with switchgear and control devices.
- Additional mounting levels.

In combination with functional space dividers and side panel modules, internal separation in accordance with Form 2, 3 or 4 is possible.

Material:

Sheet steel, zinc-plated, passivated, 2 mm

Supply includes:

Angle brackets and assembly parts.

For the version with cable entry:

Additional square cut-out with insulating plates for sealing the cut-out.



Also required:

Functional space side panel modules, see page 43.

For enclosure width mm	For compartment height mm	Width mm	Height mm	With cable entry	Packs of	Model No. SV
400	150	302	143	–	1	9673.641
400	200	302	193	–	1	9673.642
400	250	302	243	–	1	9673.647
400	300	302	293	–	1	9673.643
400	400	302	393	–	1	9673.644
400	600	302	593	–	1	9673.646
400	800	302	793	–	1	9673.648
400	1000	302	993	–	1	9673.640
400	150	302	143	■	1	9673.651
400	200	302	193	■	1	9673.652
400	250	302	243	■	1	9673.657
400	300	302	293	■	1	9673.653
400	400	302	393	■	1	9673.654
600	150	502	143	–	1	9673.661
600	200	502	193	–	1	9673.662
600	250	502	243	–	1	9673.667
600	300	502	293	–	1	9673.663
600	400	502	393	–	1	9673.664
600	600	502	593	–	1	9673.666
600	800	502	793	–	1	9673.668
600	1000	502	993	–	1	9673.660
600	150	502	143	■	1	9673.671
600	200	502	193	■	1	9673.672
600	250	502	243	■	1	9673.677
600	300	502	293	■	1	9673.673
600	400	502	393	■	1	9673.674
800	150	702	143	–	1	9673.681
800	200	702	193	–	1	9673.682
800	250	702	243	–	1	9673.687
800	300	702	293	–	1	9673.683
800	400	702	393	–	1	9673.684
800	600	702	593	–	1	9673.686
800	800	702	793	–	1	9673.688
800	1000	702	993	–	1	9673.680
800	150	702	143	■	1	9673.691
800	200	702	193	■	1	9673.692
800	250	702	243	■	1	9673.697
800	300	702	293	■	1	9673.693
800	400	702	393	■	1	9673.694



Support frame

for DIN rail-mounted devices

Support frame set for accepting DIN rail-mounted devices (e.g. MCBs). The support rails are fastened with two mounting brackets to the side panel modules. The cover is fastened to the support frame with knurled screws. In combination with functional space dividers, partial mounting plates and side panel modules, separation in accordance with Form 2, 3 or 4 is possible.

Material:

Support frame:
Sheet steel, zinc-plated, passivated, 1.5 mm
Cover: Sheet steel, spray-finished, 1.5 mm

Supply includes:

2 support rails,
2 mounting brackets,
1 front trim panel with cut-out,
incl. assembly parts.

For enclosure width mm	For compartment height mm	No. of pitch units 17.5 mm	Packs of	Model No. SV
600	150	1 x 24	1 set	9674.761
600	300	2 x 24	1 set	9674.762
600	600	3 x 24	1 set	9674.763
600	600	4 x 24	1 set	9674.764
800	150	1 x 36	1 set	9674.781
800	300	2 x 36	1 set	9674.782
800	600	3 x 36	1 set	9674.783
800	600	4 x 36	1 set	9674.784



Also required:

Functional space side panel modules, see page 43.
Partial mounting plates, see page 48.



Mini-TS profiles 17 x 15.5 mm

for TS

Mounting angle with TS pitch on three sides. Suitable for

- building an auxiliary construction for dividing the busbar space,
- individual use as mounting frame for low and medium loads,
- fastening in the internal or external mounting level of the TS 8 enclosure.

Material:

Sheet steel, zinc-plated, passivated, 1.5 mm



Also required:

Frame connector piece, see page 50.
T-connector piece, see page 50.
Corner connector, see page 50.



For horizontal busbar space separation		Packs of	Model No. SV
For compartment depth mm	Length mm		
425	62.5	12	9673.915
600	137.5	12	9673.920

For vertical busbar space separation		Packs of	Model No. SV
For compartment height mm	Length mm		
350	337.5	12	9673.942
400	387.5	12	9673.943
450	437.5	12	9673.952
500	487.5	12	9673.953
650	637.5	12	9673.972
700	687.5	12	9673.973
750	737.5	12	9673.982
800	787.5	12	9673.983

For external mounting level		Packs of	Model No. SV
For enclosure width/depth mm	Length mm		
300	162.5	12	9673.930
400	262.5	12	9673.940
500	362.5	12	9673.950
600	462.5	12	9673.960
800	662.5	12	9673.980

For internal mounting level		Packs of	Model No. SV
For enclosure width/depth mm	Length mm		
300	212.5	12	9673.931
400	312.5	12	9673.941
500	412.5	12	9673.951
600	512.5	12	9673.961
800	712.5	12	9673.981

Form 2-4 compartment

Compartment configuration



Frame connector piece

for Mini-TS profile

Mounting part with integral M4 threads for attaching the Mini-TS profile to the horizontal and vertical TS frame section (external level). The frame adaptor piece can be used as a self-holding construct in the TS pitch and fastened with a screw to the frame. Can also be used for fastening other sections with TS pitch.

Material:

Die-cast zinc

Supply includes:

Assembly parts.

Packs of	Model No. SV
24	9673.901



T-connector piece

for Mini-TS profile

Mounting part with integrated M4 threads for fastening the Mini-TS profile to the

- horizontal and vertical TS chassis,
- Mini-TS profile,
- vertical TS frame section (internal level).

The T-connector piece can be used as a self-holding construct in the TS pitch and fastened with a screw to the frame. Can also be used for fastening other sections with TS pitch.

Material:

Die-cast zinc

Supply includes:

Assembly parts.

Packs of	Model No. SV
24	9673.903



Corner connector

for Mini-TS profile

Mounting part with integrated M4 threads for connecting two Mini-TS profiles at an angle of 90° at the corner. Required for building the auxiliary construction for the busbar space separation.

Material:

Die-cast zinc

Supply includes:

Assembly parts.

Packs of	Model No. SV
10	9673.902

Form 2-4 compartment

Compartment configuration

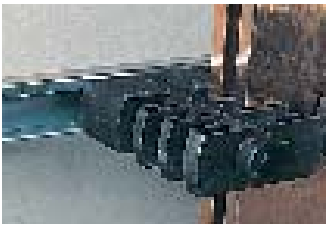

Stacking insulator

To support the connection kits top/bottom for open power circuit-breakers. Easily retro-fitted.

Supply includes:
Assembly parts.

Packs of	Model No. SV
6	9660.200



Also required:

Support rail for stacking insulator, see page 51.

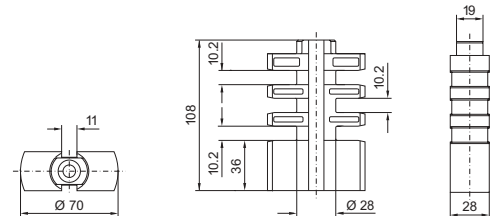

Support rails for stacking insulator

For attaching to the outer mounting level of the TS 8 enclosure and for the configuration of stacking insulators.

Material:
Sheet steel, zinc-plated, passivated

Supply includes:
Assembly parts.

For enclosure width mm	Packs of	Model No. SV
400	2	9676.194
600	2	9676.196
800	2	9676.198





Safe, flexible and fast – Rittal busbar technology

Time-saving assembly, diverse application options, individual modularity and a high level of operational safety – these are the benefits of the Rittal RiLine60 busbar systems. Simply insert the bars, secure – and it's done! This is how quickly a variety of copper cross-sections may be mounted in the support. Simple assembly and safe contacting, coupled with a broad selection of connection and component support adaptors and fuse elements are the prerequisites for efficient assembly and operation.

Form 2-4 busbar systems

RiLine60 up to 1600 A

Safety



Rittal busbar systems use proven and tested system components to provide a high level of safety.



Fully-insulated busbar system with finger-safe **contact hazard protection protection**, also at the connection points.



Increased arcing safety thanks to **busbar system installed without any base points** and busbar holders with arcing fault prevention.



All plastic materials used for the busbar system are **self-extinguishing** (fire behaviour in accordance with UL 94-V0).

Busbar system



Rittal busbar systems – modular and compact.



Each rated current, each construction form and each required short-circuit resistance has a busbar system appropriate for the enclosure.



Pre-assembled **busbar connection adaptors** ensure simple, safe handling.



As well as enabling you to optimise your assembly, the **tested component adaptors** and the alternative indoor busbar system also saves valuable installation and servicing time.

Fuse elements



Simple planning, compact designs, fast assembly, reliable contacting.



Bus-mounting fuse bases for snap-on mounting. The three-pole components ensure reliable-contact, shake-proof connection with the busbars.



RiLine NH isolators. The contact swivel feet have one outstanding function: The cable outlet can be switched from bottom to top in a matter of seconds.



NH fused isolator. With a build width of just 50 mm, it sets new standards in compact, space-saving configuration.



Modular outgoing panel with distributor bar system

Inside the compartment

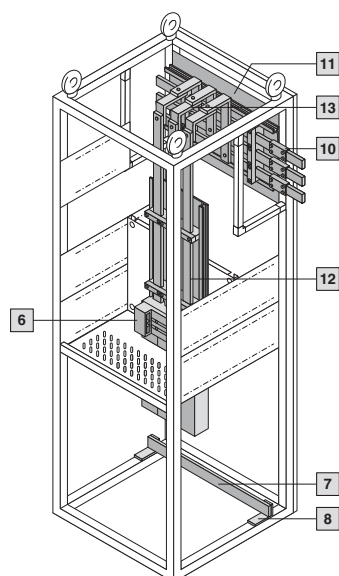

Behind the compartment

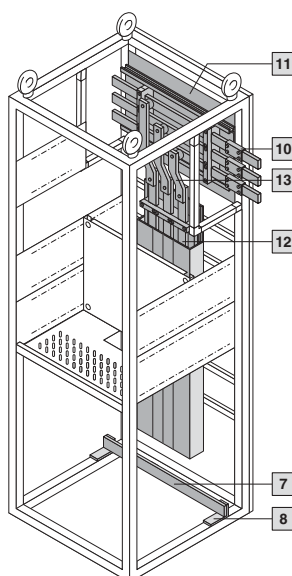

Flat copper bar system

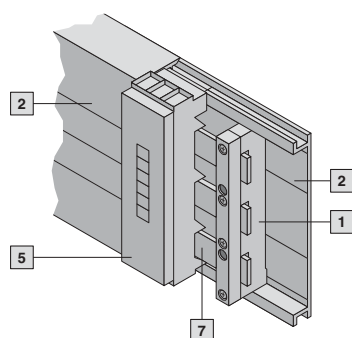

PLS busbar system

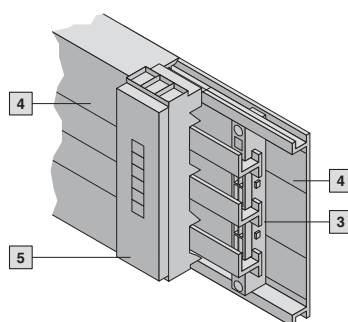

Cable chamber

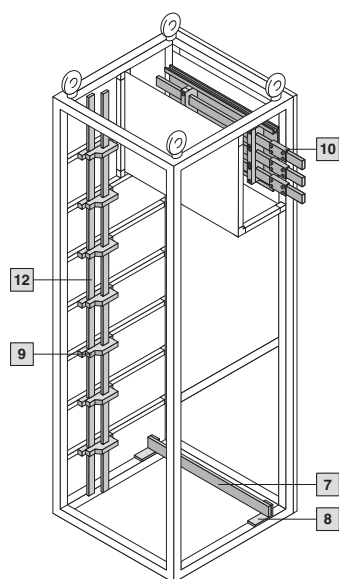

Busbar components for the configuration of modular or cable chamber enclosures with a busbar system. Components must be selected depending on the required rated current and the associated system components. Connection and cover components should be selected according to requirements. We highly recommend the software Rittal Power Engineering to assist with selection – see Cat. 32, page 1153.

Components	Page
1 Busbar supports (3-pole)	56
2 System components (3-pole)	57
3 PLS busbar supports (3-pole)	58
4 PLS system components (3-pole)	59
5 Busbar connection adaptor (3-pole)	60/61
6 Circuit-breaker component adaptor (3-pole)	62/63
1 Busbar supports (4-pole)	64
2 System components (4-pole)	65
3 Busbar supports PLUS (4-pole)	66
4 PLS system components (4-pole)	67
5 Busbar connection adaptor (4-pole)	68/69
6 Circuit-breaker component adaptor (4-pole)	70
7 Busbars	88
8 PE/PEN combination angle	89
9 Busbar support N-PE	88
10 Busbar connectors	90
11 System attachments	92
12 Distribution busbars	92
13 T-connection kits	91
PLS busbar connectors	90
PLS expansion connectors	90
Busbar cover section	88
Base isolators	89

Form 2-4 busbar systems

Busbar supports (3-pole)

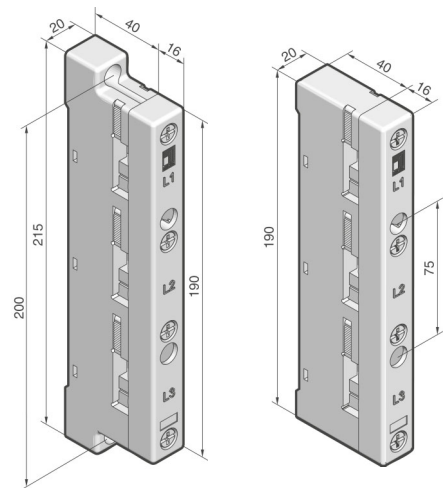

Material:
Polyamide (PA 6.6),
25 % fibreglass-reinforced.
Continuous operating
temperature max. 130°C.
Fire protection corresponding
to UL 94-V0.

Colour:
RAL 7035

**Short-circuit protection
diagram,**
see page 98.

Technical information
for the calculation of rated
currents,
see page 100.

1 With attachment
holes on the outside

2 With attachment
holes on the inside

Version	Packs of	1 External attachment	2 Internal attachment	Page
Number of poles		3-pole	3-pole	
Bar centre distance		60 mm	60 mm	
For busbars E-Cu		12 x 5/10 mm ¹⁾ , 15 x 5 – 30 x 10 mm		
Tightening torque				
● Assembly screw (M5 x 16)		3 – 5 Nm	3 – 5 Nm	
● Cover attachment		1 – 3 Nm	1 – 3 Nm	
Model No. SV	4	9340.010	9340.000	
Accessories				
3 End covers for side contact hazard protection	2	9340.070	9340.070	
Spacers for SV 9340.000/010	12	9340.090	9340.090	96

¹⁾ If 12 x 5/10 mm busbars are used, the spacer SV 9340.090 is additionally required.

Busbars E-Cu

To DIN EN 13 601.
Length: 2400 mm/bar.

Dimensions mm	Packs of	Model No. SV	Page
12 x 5	6	3580.000	88
12 x 10	6	3580.100	
15 x 5	6	3581.000	
15 x 10	6	3581.100	
20 x 5	6	3582.000	
20 x 10	6	3585.000	
25 x 5	6	3583.000	
30 x 5 ¹⁾	6	3584.000 ²⁾	
30 x 10 ¹⁾	6	3586.000 ²⁾	
Accessories			
Busbar cover section (length 1 m/each)	10	3092.000	88
Busbar connector for E-Cu			
4 12 x 5 – 15 x 10 mm (single connection)	3	9350.075	90
5 20 x 5 – 30 x 10 mm (single connection)	3	9320.020	90
6 20 x 5 – 30 x 10 mm (bayed connection) ³⁾	3	9320.030	90

¹⁾ Other busbar lengths, see page 89.

²⁾ Tin-plated version available on request.

³⁾ From enclosure to enclosure.

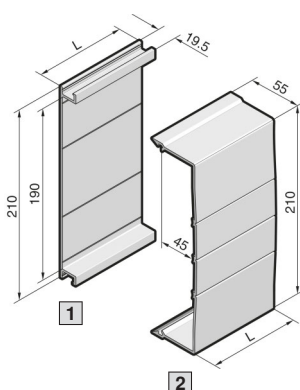

1 Base tray

For rear contact hazard protection of the flat bar assembly.

Length (L) mm	Packs of	Model No. SV
500	2	9340.100
700	2	9340.110
900	2	9340.120
1100	2	9340.130
2400	1	9340.170

2 Cover section

May be cut to length as required; for clip-on mounting to the base tray.

Length (L) mm	Packs of	Model No. SV
700	2	9340.200
1100	2	9340.210

Base tray and cover section

Material:

Thermally modified hard PVC.
Continuous operating temperature max. 91°C.
Fire protection corresponding to UL 94-V0.

Colour:

RAL 7035

Note:

If the cover section is mounted from the front, the support panel (SV 9340.220) is needed for stability.

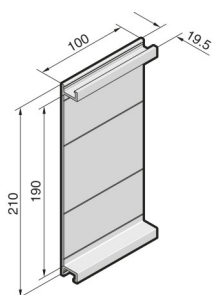

Base tray infill

For rear contact hazard protection when connecting the busbars from enclosure to enclosure.

Material:

Thermally modified hard PVC.
Continuous operating temperature max. 91°C.
Fire protection corresponding to UL 94-V0.

Colour:

RAL 7035

Packs of	Model No. SV
2	9340.140

Supply includes:

Assembly parts.



Support panel

for cover section

To prevent side access to the cover section. The support panel also provides additional stability.

Material:

Polyamide (PA 6.6).
Continuous operating temperature max. 105°C.
Fire protection corresponding to UL 94-V0.

Colour:

RAL 7035

Packs of	Model No. SV
5	9340.220

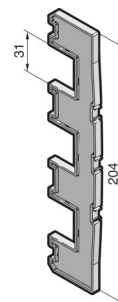

Form 2-4 busbar systems

PLS busbar supports (3-pole)

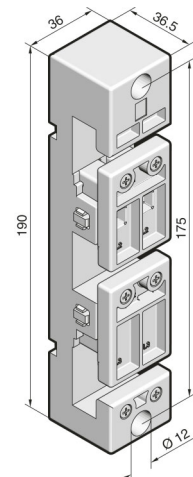
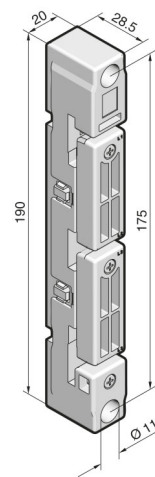
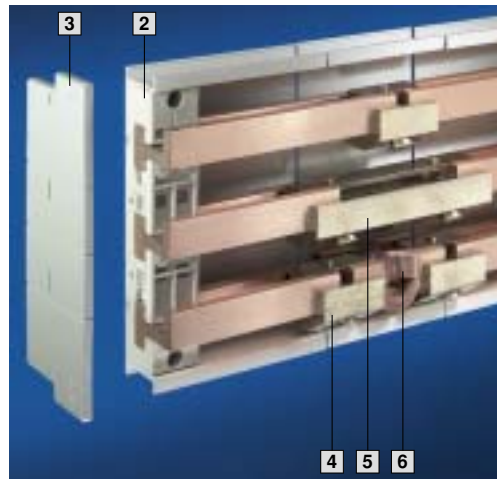

1 Rittal PLS 800

2 Rittal PLS 1600

Material:

Polyamide (PA 6.6),
25 % fibreglass-reinforced.
Continuous operating
temperature max. 130°C.
Fire protection corresponding
to UL 94-V0.

Colour:

RAL 7035

Short-circuit protection diagram,

see page 98.

Technical information

for the calculation of rated
currents,
see page 100.

For Rittal system	Packs of	1 PLS 800	2 PLS 1600
Number of poles		3-pole	3-pole
Bar centre distance		60 mm	60 mm
Tightening torque			
● Assembly screw (M5 x 20)		3 – 5 Nm	3 – 5 Nm
● Busbar anti-slip guard		0.7 Nm	0.7 Nm
Model No. SV	4	9341.000	9342.000
Accessories			
3 End covers for contact hazard protection on the sides	2	9341.070	9342.070

PLS special busbars

made from E-Cu

For Rittal system		Packs of	PLS 800		PLS 1600		Page
Cross-section			300 mm ²		900 mm ²		
Bar thickness			5 mm		10 mm		
Length mm	For enclosure width mm		Model No. SV		Model No. SV		
			E-Cu	E-Cu, tin-plated	E-Cu	E-Cu, tin-plated	
495	600 ¹⁾	3	3524.000	3524.200²⁾	3527.000	3527.200²⁾	
695	800 ¹⁾	3	3525.000	3525.200²⁾	3528.000	3528.200²⁾	
895	1000 ¹⁾	3	3525.010	3525.210²⁾	3528.010	3528.210²⁾	
1095	1200 ¹⁾	3	3526.000	3526.200²⁾	3529.000	3529.200²⁾	
2400	variable	1	3509.000	3509.200²⁾	3516.000	3516.200²⁾	
Accessories							
4 PLS busbar connector (single connection)		3	3504.000		3514.000		90
5 PLS busbar connector (bayed connection) ³⁾		3	3505.000		3515.000		90
6 PLS expansion connectors ⁴⁾		3	9320.060		9320.070		90

¹⁾ For Rittal TS 8/ES enclosure systems.

²⁾ Delivery times available on request.

³⁾ From enclosure to enclosure

⁴⁾ Two PLS rail connectors (single connection) are required to fit one expansion connector.

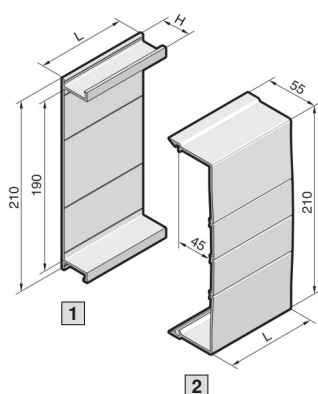

1 Base tray

For rear contact hazard protection of the PLS busbar assembly.

Length (L) mm	Packs of	Model No. SV For system	
		PLS 800	PLS 1600
500	2	9341.100	9342.100
700	2	9341.110	9342.110
900	2	9341.120	9342.120
1100	2	9341.130	9342.130
2400	1	9341.170	9342.170
Height (H) mm		32	43

2 Cover section

May be cut to length individually, for clip-on mounting to the base tray for PLS system 800 A and 1600 A.

Length (L) mm	Packs of	Model No. SV
700	2	9340.200
1100	2	9340.210

Base tray and cover section

Material:

Thermally modified hard PVC.
Continuous operating temperature max. 91°C.
Fire protection corresponding to UL 94-V0.

Colour:

RAL 7035

Note:

If the cover section is mounted from the front, the support panel (SV 9340.220) is needed for stability.

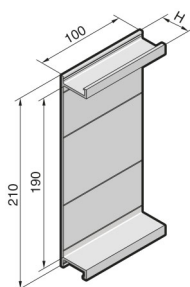

Base tray infill

For rear contact hazard protection when connecting the busbars from enclosure.

Material:

Thermally modified hard PVC.
Continuous operating temperature max. 91°C.
Fire protection corresponding to UL 94-V0.

Colour:

RAL 7035

For system	Height (H) mm	Packs of	Model No. SV
PLS 800	32	2	9341.140
PLS 1600	43	2	9342.140

Supply includes:

Assembly parts.



Support panel

for cover section

To prevent side access to the cover section. The support panel also provides additional stability.

Material:

Polyamide (PA 6.6).
Continuous operating temperature max. 105°C.
Fire protection corresponding to UL 94-V0.

Colour:

RAL 7035

Packs of	Model No. SV
5	9340.220

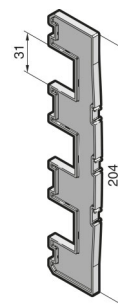

Form 2-4 busbar systems

Busbar connection adaptor (3-pole)

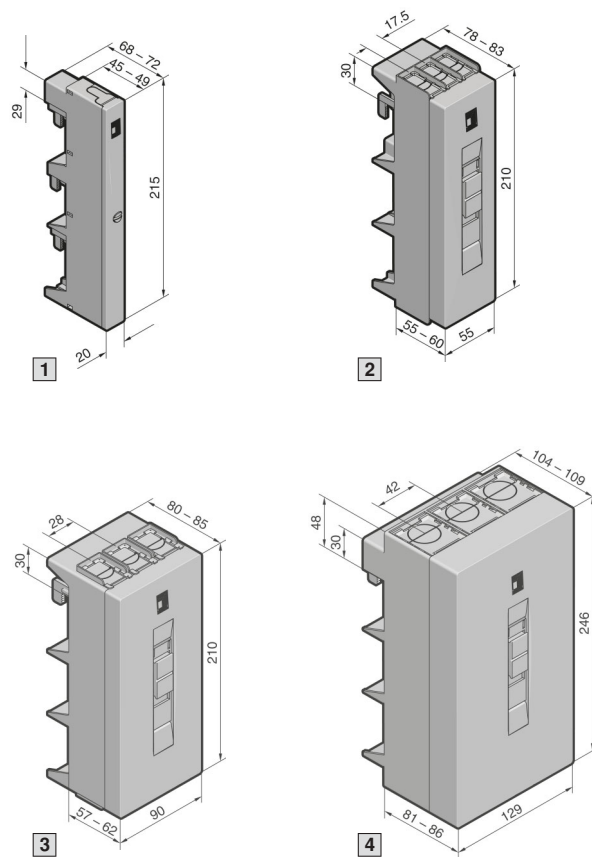
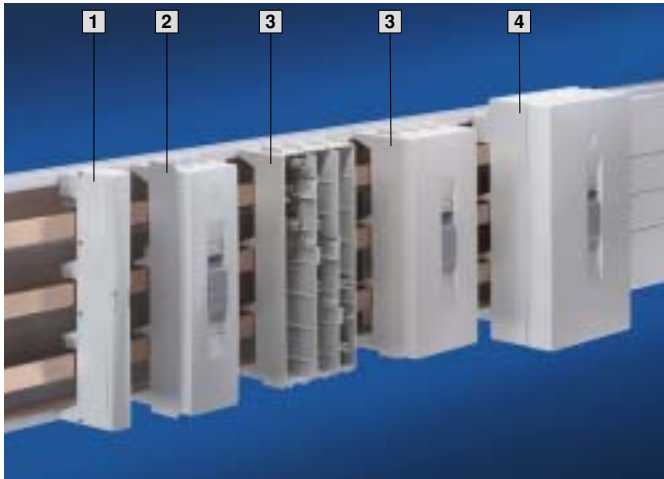

Material:

Punched section

Polyamide (PA 6.6),
25 % fibreglass-reinforced.
Continuous operating
temperature max. 130°C.
Fire protection corresponding
to UL 94-V0.

Cover

ABS,
fire protection corresponding
to UL 94-V0.

Colour:

RAL 7035

Supply includes:

Cover.

Design (3-pole)	Packs of	1	2	3	4	Page
Rated current up to		63 A	125 A	250 A	800 A	
Rated operating voltage		690 V~	690 V~	690 V~	690 V~	
Connection of round conductors						
● Fine wire with wire end ferrule		2.5 – 10 mm ²	10 – 25 mm ²	35 – 120 mm ²	95 – 185 mm ²	
● Multi-wire		2.5 – 16 mm ²	16 – 35 mm ²	35 – 120 mm ²	95 – 300 mm ²	
● Solid		2.5 – 16 mm ²	–	–	–	
Clamping area for laminated copper bars		–	10 x 7.8 mm	18.5 x 15.5 mm	33 x 20 mm	
Tightening torque						
● Assembly screw		2 Nm	2 Nm	4 – 6 Nm	6 Nm	
● Terminal screw		2.5 Nm	2 – 3 Nm	12 Nm	12 – 14 Nm	
For bar thickness		5/10 mm	5/10 mm	5/10 mm	5/10 mm	
Outlet top/bottom						
Model No. SV	1	–	9342.220	9342.250	9342.280	
Outlet at top						
Model No. SV	1	9342.200	9342.230	9342.260	9342.290	
Outlet at bottom						
Model No. SV	1	9342.210	9342.240	9342.270	9342.300	
Accessories						
Laminated copper bars		–	■	■	■	95

Form 2-4 busbar systems

Busbar connection adaptor (3-pole)

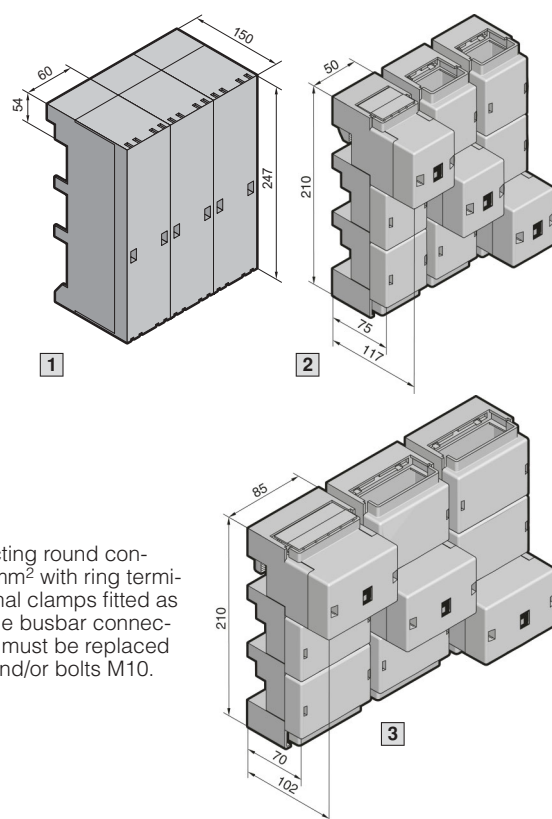
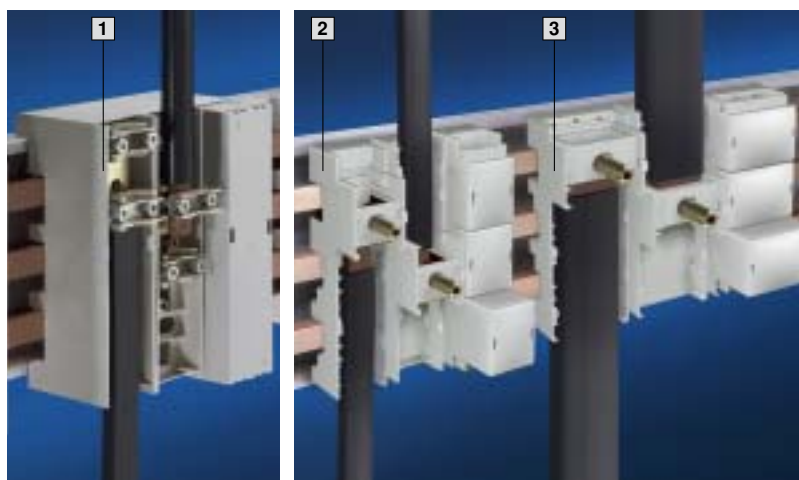

Material:
Punched section
SV 3439.010

Fibreglass-reinforced, thermo-plastic polyester (PBT).
Continuous operating temperature max. 140°C.
Fire protection corresponding to UL 94-V0.

SV 9342.310/.320

Polyamide (PA 6.6), 25 % fibreglass-reinforced.
Continuous operating temperature max. 130°C.
Fire protection corresponding to UL 94-V0.

Cover

ABS,
fire protection corresponding to UL 94-V0.

Colour:
RAL 7035

Supply includes:
Cover.

SV 3439.010

When connecting round conductors 300 mm² with ring terminal, the terminal clamps fitted as standard in the busbar connection adaptors must be replaced with screws and/or bolts M10.

Version (3 x 1-pole)	Packs of	1	2	3	Page
Rated current up to		600 A	800 A	1600 A	
Rated operating voltage		690 V~	690 V~	690 V~	
Outlet		top/bottom	top/bottom	top/bottom	
Connection of round conductors					
● Fine wire with wire end ferrule		35 – 240 mm ²	95 – 185 mm ²	–	
● Multi-wire		35 – 240 mm ²	95 – 300 mm ²	–	
Clamping area for laminated copper bars					
● For 5 mm bar thickness		24 x 21 mm	33 x 27 mm	65 x 27 mm	
● For 10 mm bar thickness		24 x 21 mm	33 x 22 mm	65 x 22 mm	
Tightening torque					
● Assembly screw		15 – 20 Nm	–	–	
● Terminal screw		15 Nm	12 – 14 Nm	15 – 20 Nm	
For bar thickness		5/10 mm	5/10 mm	5/10 mm	
Model No. SV	1 set	3439.010	9342.310	9342.320	
Accessories					
Laminated copper bars		■	■	■	95

Form 2-4 busbar systems

Component adaptors 100 A/circuit-breaker component adaptors 125 A, 160 A (3-pole)

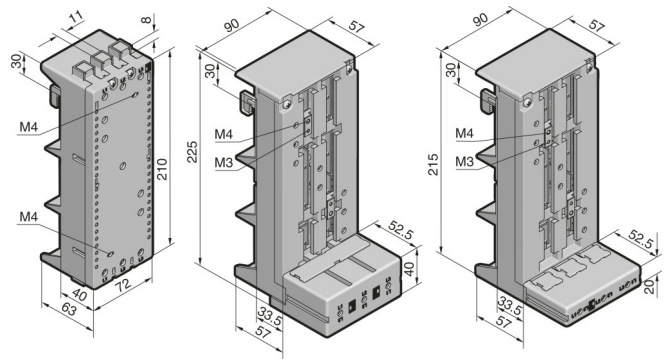
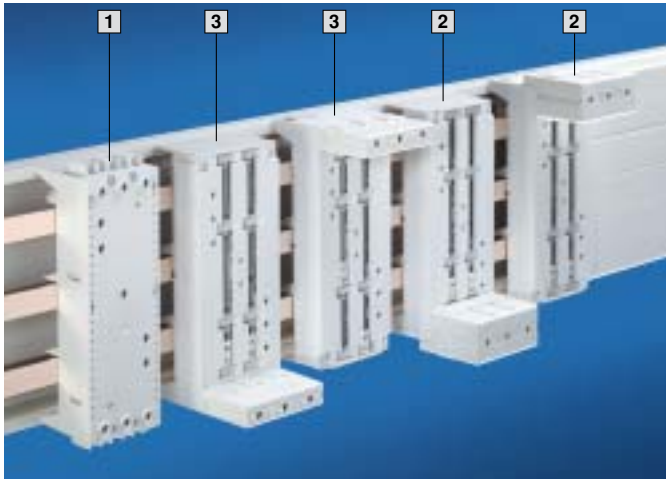

1 SV 9342.400
SV 9342.410

2 SV 9342.540

3 SV 9342.500

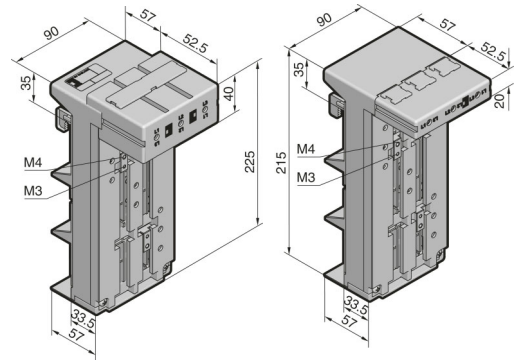

2 SV 9342.550

3 SV 9342.510

Material:

Polyamide (PA 6.6),
25 % fibreglass-reinforced.
Continuous operating
temperature max. 130°C.
Fire protection corresponding
to UL 94-V0.

Scope of supply Circuit-breaker component adaptor:

Terminal cover and sliding
blocks for switchgear attach-
ment.

Colour:

RAL 7035

Version	Packs of	1 Component adaptor	2 Circuit-breaker component adaptor	3 Circuit-breaker component adaptor	Page
Construction width		72 mm	90 mm	90 mm	
Length		210 mm	225 mm	215 mm	
Rated current up to		100 A	125 A	160 A	
Rated operating voltage		690 V~	690 V~		
Connection clamp		Box terminal	Box terminal		
Connection of round conductors		10 – 35 mm ²	35 – 120 mm ²		
Clamping area for laminated copper bars		10 x 7.8 mm	18.5 x 15.5 mm		
Tightening torque					
● Terminal screw		2 – 3 Nm	12 Nm		
● Rail attachment		2 Nm	4 – 6 Nm		
● Switchgear attachment		1.5 Nm	1.5 Nm		
For switchgear make/model	ABB	MS497	S2, T1, T2		
	GE	–	FD		
	Merlin Gerin	–	NS80, NSC100		
	Moeller Electric	PKZ2 ¹⁾	NZM1		
	Siemens	S3	–		
	Telemecanique	GV3 ¹⁾	–		
Universal application	■ ¹⁾	–			
For bar thickness		5/10 mm	5/10 mm		
Cable outlet at the top ²⁾ Model No. SV	1	9342.400	9342.540	9342.500	
Cable outlet at the bottom ²⁾ Model No. SV	1	9342.410	9342.550	9342.510	
Accessories					
Support rail Width 72 mm, height 15 mm	5	9320.120	–	–	96
Sliding blocks	6	–	9342.560	9342.560	96
Connection bracket		–	■	■	97

¹⁾ Mounting only possible with support rail SV 9320.120.

²⁾ Switch outlet or outgoing cable.

Form 2-4 busbar systems

Circuit-breaker component adaptors 250 A/630 A (3-pole)

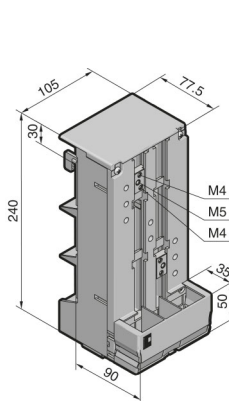
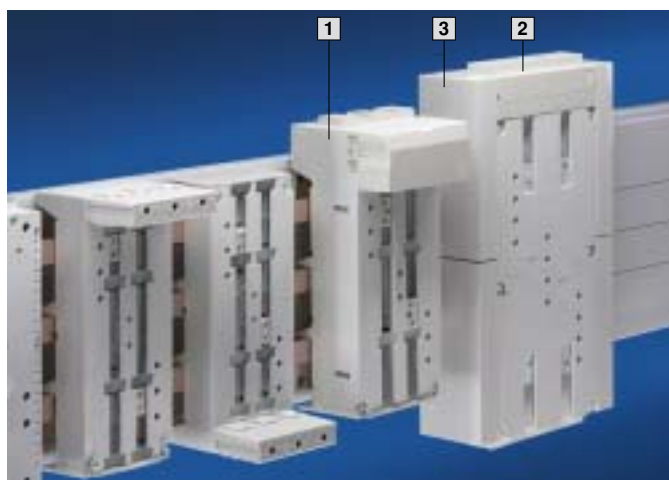

1 SV 9342.600

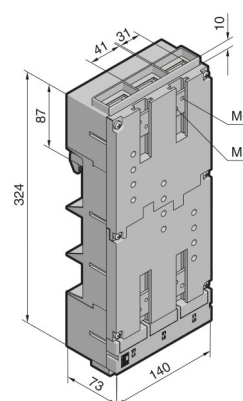

2 SV 9342.700

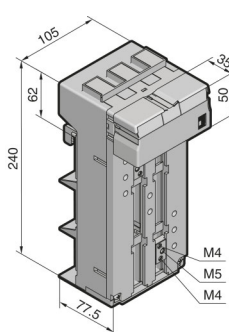

1 SV 9342.610

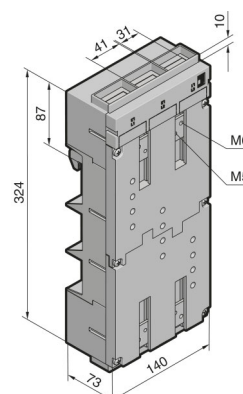

2 SV 9342.710

Material:
Polyamide (PA 6.6),
25 % fibreglass-reinforced.
Continuous operating
temperature max. 130°C.
Fire protection corresponding
to UL 94-V0.

Colour:
RAL 7035

Supply includes:
Terminal cover and sliding
blocks for switchgear attach-
ment.

Version	Packs of	1	2	Page
Construction width		105 mm	140 mm	
Length		240 mm	324 mm	
Rated current up to		250 A	630 A	
Rated operating voltage		690 V~	690 V~	
Connection clamp		Box terminal	Screw terminal M10	
Connection of round conductors		35 – 120 mm ²	max. 150 mm ² 2)	
Clamping area for laminated copper bars		18.5 x 15.5 mm	32 x 10 mm	
Tightening torque				
● Terminal screw		12 Nm	30 – 32 Nm	
● Rail attachment		4 – 6 Nm	12 – 14 Nm	
● Switchgear attachment		1.5 Nm	2.5 Nm	
For switchgear make/model	ABB	S3, T3, T4	S5, T5	
	GE	FE	–	
	Merlin Gerin	NS100, NS160, NS250	NS400, NS630	
	Moeller Electric	NZM2	NZM3	
	Siemens	VL160X, VL160, VL250	VL400, VL630 ³⁾	
	Telemecanique	GV7	–	
For bar thickness		5/10 mm	5/10 mm	
Cable outlet at the top ¹⁾ Model No. SV	1	9342.600	9342.700	
Cable outlet at the bottom ¹⁾ Model No. SV	1	9342.610	9342.710	
Accessories				
3) Insert strip 25 mm to extend the construction width from 140 mm to 190 mm	4 (1 set)	–	9342.720	96
Sliding blocks	6	9342.640	–	96
Connection bracket		■	■	97

¹⁾ Switch outlet or outgoing cable.

²⁾ With ring terminal.

³⁾ Also required: Insert strip 25 mm (SV 9342.720).

Form 2-4 busbar systems

Busbar supports (4-pole)

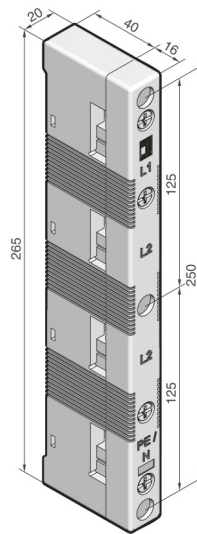
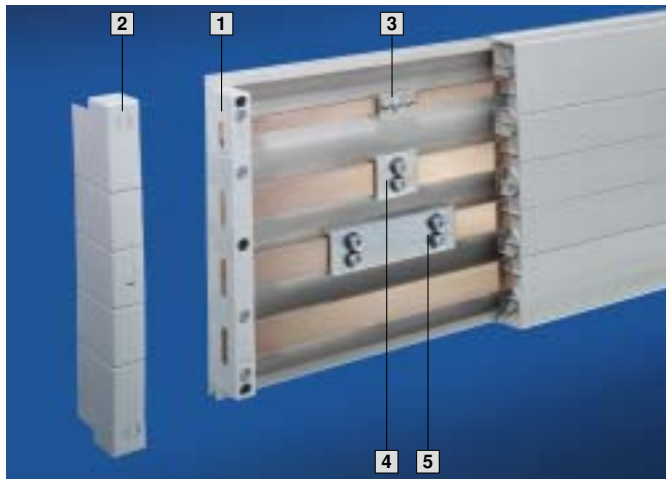

1 With attachment holes on the inside

Material:

Polyamide (PA 6.6),
25 % fibreglass-reinforced.
Continuous operating
temperature max. 130°C.
Fire protection corresponding
to UL 94-V0.

Colour:

RAL 7035

**Short-circuit protection
diagram,**
see page 99.

Technical information
for the calculation of rated
currents,
see page 100.

Design	Packs of	1	Page
Number of poles		4-pole	
Bar centre distance		60 mm	
For busbars E-Cu		12 x 5/10 mm ¹⁾ , 15 x 5 – 30 x 10 mm	
Tightening torque			
● Assembly screw (M5 x 25)		3 – 5 Nm	
● Cover attachment		1 – 3 Nm	
Model No. SV	4	9340.004	
Accessories			
2 End covers for contact hazard protection on the sides	2	9340.074	
Spacers for SV 9340.004	12	9340.090	96

¹⁾ If 12 x 5/10 mm busbars are used, the spacer SV 9340.090 is additionally required.

Busbars E-Cu

To DIN EN 13 601.

Length: 2400 mm/bar.

Dimensions mm	Packs of	Model No. SV	Page
12 x 5	6	3580.000	88
12 x 10	6	3580.100	
15 x 5	6	3581.000	
15 x 10	6	3581.100	
20 x 5	6	3582.000	
20 x 10	6	3585.000	
25 x 5	6	3583.000	
30 x 5 ¹⁾	6	3584.000 ²⁾	
30 x 10 ¹⁾	6	3586.000 ²⁾	
Accessories			
Busbar cover section (length 1 m/each)	10	3092.000	88
Busbar connector for E-Cu			
3 12 x 5 – 15 x 10 mm (single connection)	3	9350.075	90
4 20 x 5 – 30 x 10 mm (single connection)	3	9320.020	90
5 20 x 5 – 30 x 10 mm (bayed connection) ³⁾	3	9320.030	90

¹⁾ Other busbar lengths, see page 89.

²⁾ Tin-plated version available on request.

³⁾ From enclosure to enclosure.

Form 2-4 busbar systems

System components (4-pole)

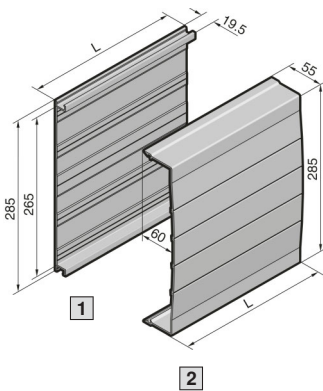

1 Base tray

For rear contact hazard protection of the flat bar assembly.

Length (L) mm	Packs of	Model No. SV
1100	2	9340.134

2 Cover section

May be cut to length as required; for clip-on mounting to the base tray.

Length (L) mm	Packs of	Model No. SV
1100	2	9340.214

Base tray and cover section

Material:

Thermally modified hard PVC.
Continuous operating temperature max. 91°C.
Fire protection corresponding to UL 94-V0.

Colour:

RAL 7035

Note:

If the cover section is mounted from the front, the support panel (SV 9340.224) is needed for stability.



Support panel

for cover section

To prevent side access to the cover section. The support panel also provides additional stability.

Material:

Polyamide (PA 6.6).
Continuous operating temperature max. 105°C.
Fire protection corresponding to UL 94-V0.

Colour:

RAL 7035

Packs of	Model No. SV
5	9340.224

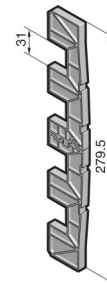

Form 2-4 busbar systems

Busbar supports PLUS (4-pole)

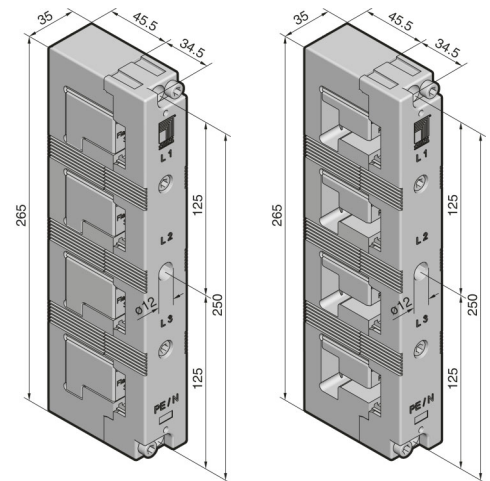
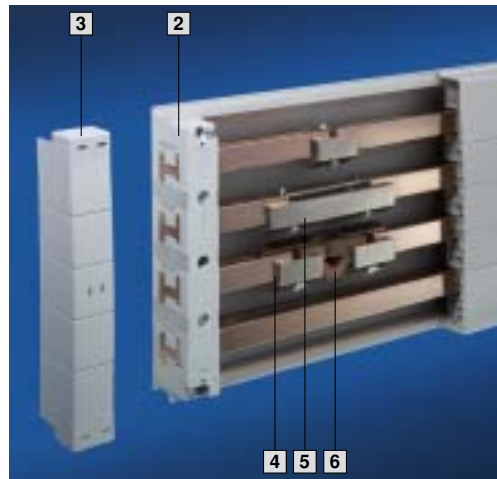

1 Rittal 30 x 10 PLUS 2 Rittal PLS 1600 PLUS

Material:
Polyamide (PA 6.6),
25 % fibreglass-reinforced.
Continuous operating
temperature max. 130°C.
Fire protection corresponding
to UL 94-V0.

Colour:
RAL 7035

**Short-circuit protection
diagram,**
see page 99.

Technical information
for the calculation of rated
currents,
see page 100.

For system	Packs of	1 Rittal 30 x 10 PLUS	2 Rittal PLS 1600 PLUS
Number of poles		4-pole	4-pole
Bar centre distance		60 mm	60 mm
For busbars E-Cu 30 x 10 mm		■	–
PLS special busbars (PLS 1600)		–	■
Tightening torque			
● Assembly screw (M6 x 20)		3 – 5 Nm	3 – 5 Nm
● Cover attachment		5 – 7 Nm	5 – 7 Nm
Model No. SV	4	9342.014	9342.004
Accessories			
3 End covers for contact hazard protection on the sides	2	9342.074	9342.074

Busbars made from E-Cu

Detailed drawing:
SV 9661.300 to .380, see page 89.

For system	Rittal 30 x 10 PLUS			Page	Rittal PLS 1600 PLUS			Page
Size	30 x 10 mm				–			
Cross-section (bar thickness)	–				900 mm ² (10 mm) ¹⁾			
For enclosure width mm	Length mm	Packs of	Model No. SV		Length mm	Packs of	Model No. SV	
300 ²⁾	265	2	9661.330	89	–	–	–	
400 ²⁾	365	2	9661.340	89	–	–	–	
600 ²⁾	565	2	9661.360	89	495	3	3527.000	58
800 ²⁾	765	2	9661.380	89	695	3	3528.000	58
1000 ²⁾	965	2	9661.300	89	895	3	3528.010	58
1200 ²⁾	1165	2	9661.320	89	1095	3	3529.000	58
Variable	2400	6	3586.000	88	2400	1	3516.000	58

Accessories								
4 PLS busbar connector (single connection)	–	–	–		–	3	3514.000	90
5 PLS busbar connector (bayed connection) ³⁾	–	–	–		–	3	3515.000	90
6 PLS expansion connectors ⁴⁾	–	–	–		–	3	9320.070	90
Baying bracket for SV 9661.300 to .380 (bayed connection)	95	4	9661.350	89	–	–	–	
Busbar connector for SV 3586.000	Single connection	–	3	9320.020	90	–	–	
	Baying connection ³⁾	–	3	9320.030	90	–	–	
Busbar cover section	1000	10	3092.000	88	–	–	–	

¹⁾ PLS special busbars (1600 A). To order tin-plated version, please add extension .2X0 to the Model No. Delivery times available on request.

²⁾ For Rittal TS 8/ES enclosure systems.

³⁾ From enclosure to enclosure.

⁴⁾ Two PLS rail connectors (single connection) are required to fit one expansion connector.

Form 2-4 busbar systems

System components (4-pole)

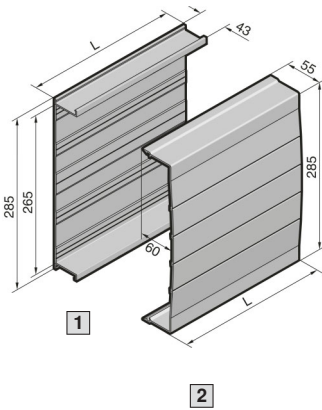

1 Base tray

For rear contact hazard protection of the busbar assembly PLUS.

Length (L) mm	Packs of	Model No. SV
1100	2	9342.134

2 Cover section

May be cut to length as required; for clip-on mounting to the base tray.

Length (L) mm	Packs of	Model No. SV
1100	2	9340.214

Base tray and cover section

Material:

Thermally modified hard PVC.
Continuous operating temperature max. 91°C.
Fire protection corresponding to UL 94-V0.

Colour:

RAL 7035

Note:

If the cover section is mounted from the front, the support panel (SV 9340.224) is needed for stability.



Support panel

for cover section

To prevent side access to the cover section. The support panel also provides additional stability.

Material:

Polyamide (PA 6.6).
Continuous operating temperature max. 105°C.
Fire protection corresponding to UL 94-V0.

Colour:

RAL 7035

Packs of	Model No. SV
5	9340.224

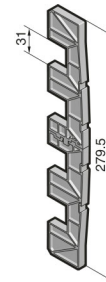

Form 2-4 busbar systems

Busbar connection adaptors (4-pole)

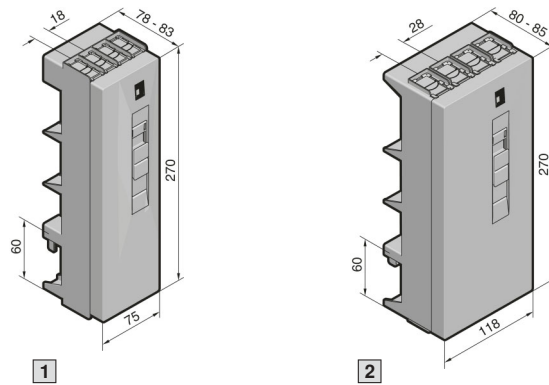
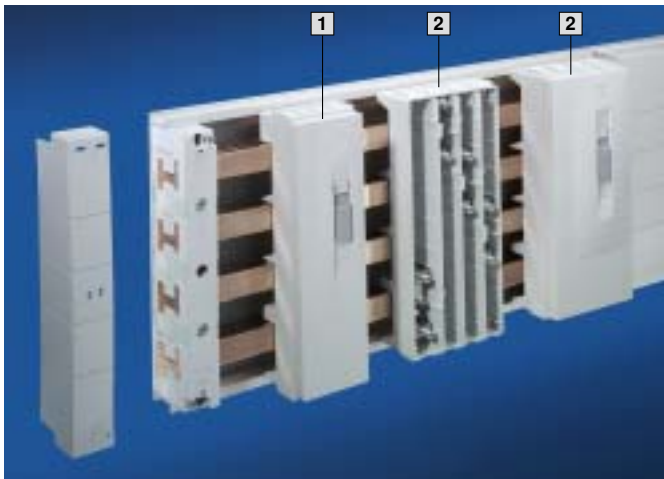

Material:

Punched section

Polyamide (PA 6.6),
25 % fibreglass-reinforced.
Continuous operating
temperature max. 130°C.
Fire protection corresponding
to UL 94-V0.

Cover

ABS,
fire protection corresponding
to UL 94-V0.

Colour:

RAL 7035

Supply includes:

Cover.

Design (4-pole)	Packs of	1	2	Page
Rated current up to		125 A	250 A	
Rated operating voltage		690 V~	690 V~	
Connection of round conductors				
● Fine wire with wire end ferrule		10 – 25 mm ²	35 – 120 mm ²	
● Multi-wire		16 – 35 mm ²	35 – 120 mm ²	
Clamping area for laminated copper bars		10 x 7.8 mm	18.5 x 15.5 mm	
Tightening torque				
● Assembly screw		2 Nm	4 – 6 Nm	
● Terminal screw		2 – 3 Nm	12 Nm	
For bar thickness		5/10 mm	5/10 mm	
Outlet top/bottom				
Model No. SV	1	9342.224	9342.254	
Outlet at top				
Model No. SV	1	9342.234	9342.264	
Outlet at bottom				
Model No. SV	1	9342.244	9342.274	
Accessories				
Laminated copper bars		■	■	95

Form 2-4 busbar systems

Busbar connection adaptors (4-pole)

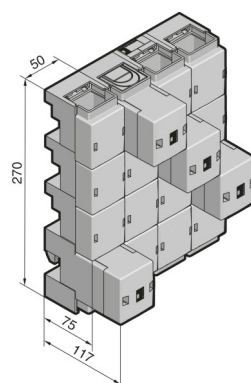
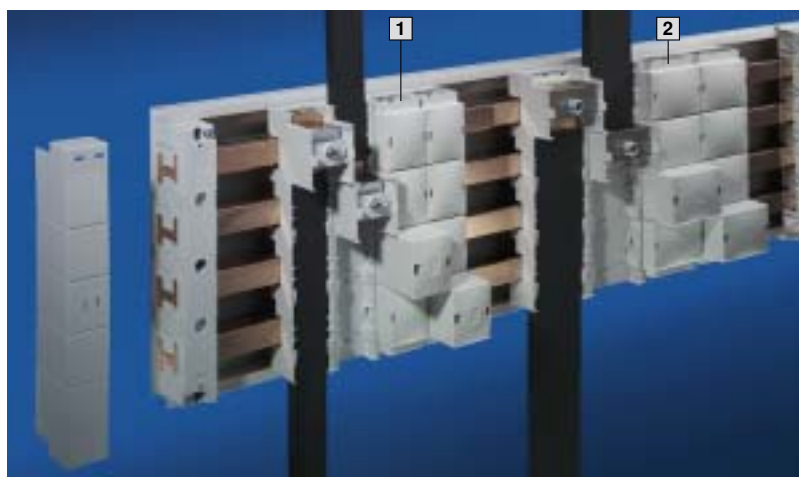

1 SV 9342.310 with SV 9342.314

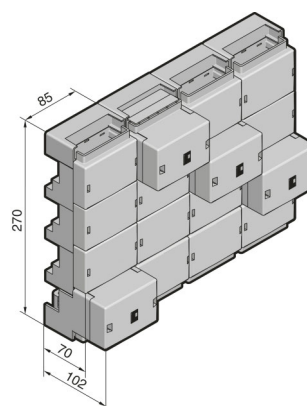

2 SV 9342.320 with SV 9342.324

Material:
Punched section
 Polyamide (PA 6.6),
 25 % fibreglass-reinforced.
 Continuous operating
 temperature max. 130°C.
 Fire protection corresponding
 to UL 94-V0.
Cover
 ABS,
 fire protection corresponding
 to UL 94-V0.

Colour:
 RAL 7035
Supply includes:
 Cover.

Design	Packs of	1	2	Page
Rated current up to		800 A	1600 A	
Rated operating voltage		690 V~	690 V~	
Outlet		top/bottom	top/bottom	
Connection of round conductors				
● Fine wire with wire end ferrule		95 – 185 mm ²	–	
● Multi-wire		95 – 300 mm ²	–	
Clamping area for laminated copper bars				
● For 5 mm bar thickness		33 x 27 mm	65 x 27 mm	
● For 10 mm bar thickness		33 x 22 mm	65 x 22 mm	
Tightening torque		12 – 14 Nm	15 – 20 Nm	
For bar thickness		5/10 mm	5/10 mm	
Busbar connection adaptors (3 x 1-pole) Model No. SV	1 set	9342.310	9342.320	
Also required				
Connection adaptor (expansion set for 4-pole configuration)	1	9342.314	9342.324	
Accessories				
Laminated copper bars		■	■	95

Form 2-4 busbar systems

Circuit-breaker component adaptors 160 A/250 A (4-pole)

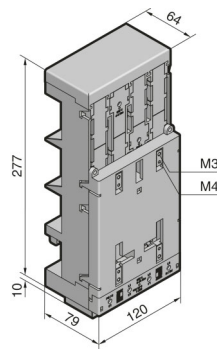

1 SV 9342.504

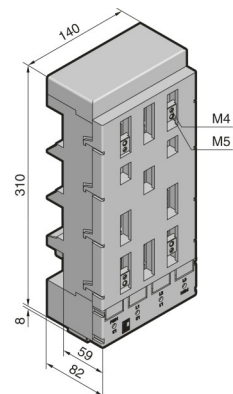

2 SV 9342.604

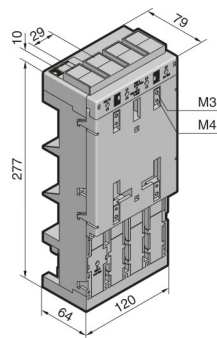

1 SV 9342.514

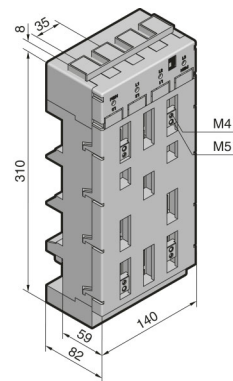

2 SV 9342.614

Material:
Polyamide (PA 6.6),
25 % fibreglass-reinforced.
Continuous operating
temperature max. 130°C.
Fire protection corresponding
to UL 94-V0.

Colour:
RAL 7035

Supply includes:
Terminal cover and sliding
blocks for switchgear attach-
ment.

Design	Packs of	1	2
Construction width		120 mm	140 mm
Length		277 mm	310 mm
Rated current up to		160 A	250 A
Rated operating voltage		690 V~	690 V~
Connection clamp		Box terminal	Box terminal
Connection of round conductors		35 – 120 mm ²	35 – 120 mm ²
Clamping area for laminated copper bars		18.5 x 15.5 mm	18.5 x 15.5 mm
Tightening torque			
● Terminal screw		12 Nm	12 Nm
● Rail attachment		4 – 6 Nm	4 – 6 Nm
● Switchgear attachment		1.5 Nm	1.5 Nm
For switchgear make/model	ABB	T1 (160 A), T2 (160 A)	T3S (250 A), T4V (315 A)
	Merlin Gerin	NSC100	NS100, NS160, NS250L
	Moeller Electric	NZM1-4 (125 A)	NZM2-4 (250 A)
	Siemens	–	VL160X, VL160, VL250
For bar thickness		5/10 mm	5/10 mm
Cable outlet at the top ¹⁾ Model No. SV	1	9342.504	9342.604
Cable outlet at the bottom ¹⁾ Model No. SV	1	9342.514	9342.614

¹⁾ Switch outlet or outgoing cable.





Two systems for optimum performance

Ingeniously simple assembly of low-voltage distributors and switchgear in the heavy current range.

The Rittal Maxi-PLS system components are supplied ready to assemble. All modules are standardised and batch-produced to ensure cost-effectiveness. One new addition to the range is the Flat-PLS, a busbar system for standard, commercially available flat bars. Whether you opt for Maxi-PLS or Flat-PLS – Ri4Power systems are the ideal links between power supply and power distribution, even down to the tiniest piece of equipment.

Form 2-4 busbar systems

Maxi-PLS and Flat-PLS up to 4000 A

Maxi-PLS



Standardised Maxi-PLS busbars in a super-compact design with an ingeniously simple attachment system.



Thanks to the **perfect system technology** and tailored dimensional pitch pattern, Maxi-PLS supports and bars ensure precise-fit, simple and fast installation.



With the aid of sliding blocks or studs, the **four attachment levels** of the Maxi-PLS busbars enable infinitely variable attachment and . . .



. . . contacting of round conductors, laminated flat copper, connection brackets and connection kits.

Flat-PLS



System configuration analogous to Maxi-PLS with standard, commercially available flat copper bars.



Flat-PLS busbar support. **Multi-variant dimensioning** of the busbars with just two supports. Also suitable for aluminium and copper-plated aluminium bars.



Longitudinal connectors for Flat-PLS. For connecting Flat-PLS busbar systems, no drilling required. Adapted to your requirements.



All-round contact hazard protection for busbars and for connection kits. Also for preventive protection against accidental arcing.

Connection components



System packages for all commercially available power circuit-breakers.



Connected to Maxi-PLS and Flat-PLS busbars using standardised components on the **connection tailored to the respective power circuit-breaker.**



The combination of **isolator chassis, contact makers and connection brackets** forms the heart of the connection.

**IEC 60 439-1
IEC 61 641**



Type-tested to EN 60 439-1/IEC 60 439-1, with ASTA certification. Special testing under accidental arcing conditions to EN 61 641/IEC 61 641.

Form 2-4 busbar systems

System components, Maxi-PLS 1600/2000

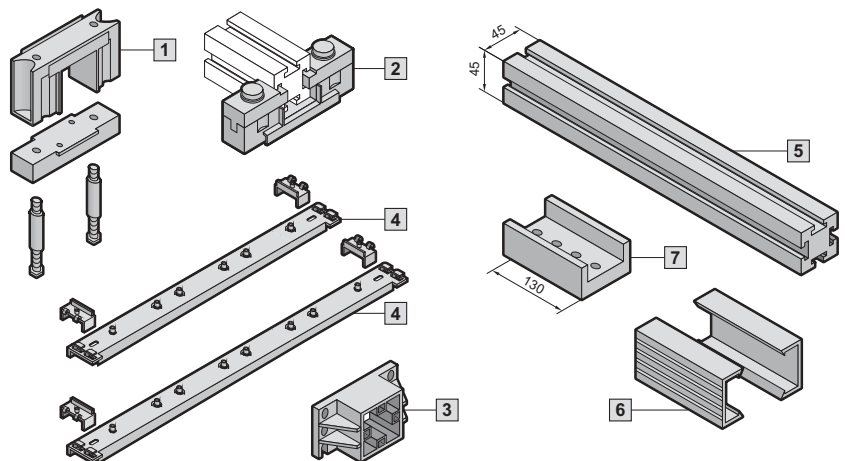

Material:
 Busbar support, end support,
 end cover: PA 6.6
 System attachment:
 Stainless steel
 Cover section: Hard PVC

Note:
 PE/PEN combination/busbars,
 see page 89.

Detailed drawing,
 see page 102.

Maxi-PLS system components			3-pole		4-pole	
			Packs of	Model No. SV	Packs of	Model No. SV
1	Busbar support	3	9640.000	3 + 1	9640.000 9649.000	
2	Busbar support, suitable for top mounting	3	9640.160	3	9640.160	
3	End support	6	9640.010	6 + 2	9640.010 9649.010	
4	System attachment for installing the busbar supports.					
	For application	For enclosure depth mm	Bar centre distance mm			
	In the roof/base section	600	100	2	9640.080	
		800	100	2	9640.088	
	Vertical coupling set	600	100	2	9649.076	
		800	100	2	9649.078	
	Rear section top/bottom	–	100	2	9640.098	
6	Cover section for clip-on mounting on the Maxi-PLS busbars, length 1000 mm.					
7	Longitudinal connector E-Cu for simple baying connection of Maxi-PLS busbars. Incl. sliding blocks, bolts, washers and nuts.					
	End cover for clip-on mounting on the end surface of Maxi-PLS busbars.	6	9640.060	6 + 2	9640.060 9649.060	
5	Maxi-PLS busbars E-Cu (special lengths available on request).					
	Length mm	For enclosure width mm	For application ¹⁾	3-/4-pole		
				1600 A	2000 A	
	491	600	A	1	9640.206	
	525	600	B	1	9640.216	
	599	600	C	1	9640.226	
	691	800	A	1	9640.236	
	725	800	B	1	9640.246	
	799	800	C	1	9640.256	
	891	1000	A	1	9640.266	
	925	1000	B	1	9640.276	
	999	1000	C	1	9640.286	
	1091	1200	A	1	9640.296	
	1125	1200	B	1	9640.306	
	1199	1200	C	1	9640.316	
	2400	–	–	3	9640.365	
	2400	–	–	–	9649.360	

¹⁾ A = Cable connection system with end support
 B = Left-hand or right-hand end enclosure in a switchgear installation
 C = Bayed enclosure with panels bayed on the left and right

Form 2-4 busbar systems

Connection components, Maxi-PLS 1600/2000

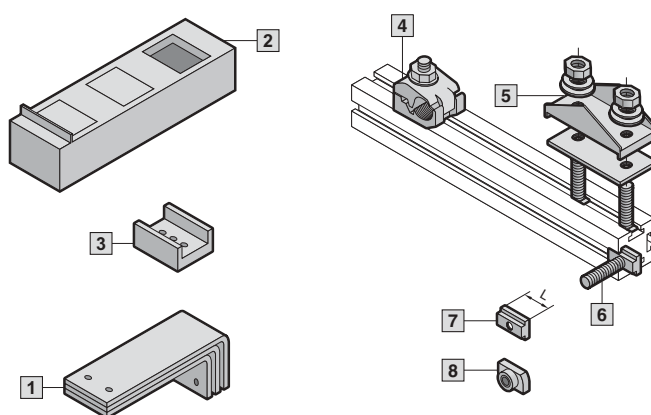

Detailed drawing,
see page 103.

Maxi-PLS connection components			3-pole		4-pole	
			Packs of	Model No. SV	Packs of	Model No. SV
1 Connection bracket E-Cu Transition from the main busbar system to the connection kits.						
For enclosure depth mm	Width mm	Number of brackets per phase				
600/800	60	1	1 set	9640.433	1 set	9640.433 + 9640.434
	60	2	1 set	9640.443	1 set	9640.443 + 9640.444
	60	3	1 set	9640.453	1 set	9640.453 + 9640.454
	100	2	1 set	9640.473	1 set	9640.473 + 9640.474
	100	3	1 set	9640.483	1 set	9640.483 + 9640.484
2 Isolator chassis for isolated routing of the connection brackets. Material: PA 6.6, black. Including assembly parts.						
Bar centre distance mm	For connection bracket width mm					
100	60		1 set	9640.020	1 set	9649.020
3 U contact maker E-Cu for contacting the connection brackets to the Maxi-PLS busbars. Including sliding blocks.						
60 mm width			3	9640.170	3 + 1	9640.170 9649.170
100 mm width			3	9640.180	3	9640.180
4 Connection clamp for the connection of round conductors 95 to 300 mm ² (single-wire and multi-wire). Including assembly parts.						
50 mm width			1	9640.325	1	9640.325
5 Connection plates for the connection of laminated flat copper bars. Including assembly parts.						
Maximum clamping area	2 x 10 x 32 x 1 mm		3	9640.330	3	9640.330
	2 x 10 x 63 x 1 mm		3	9640.340	3	9640.340
	2 x 10 x 100 x 1 mm		3	9640.350	3	9640.350
6 Terminal stud for connecting cables with ring terminals. Including sliding blocks.						
Thread	M12	Length 30 mm	3	9640.370	3	9640.370
	M16	Length 30 mm	3	9640.380	3	9640.380
7 Sliding blocks for sliding into the Maxi-PLS busbar section at the sides.						
Thread	M8	Length (L) 20 mm	15	9640.970	15	9640.970
	M10	Length (L) 25 mm	15	9640.980	15	9640.980
8 Sliding nuts for retrospective insertion into the Maxi-PLS busbar section.						
Thread	M6		15	9640.900	15	9640.900
	M8		15	9640.910	15	9640.910
	M10		15	9640.920	15	9640.920
Threaded bolts for individual connection options ¹⁾ . Including plain washers, spring lock washers and nuts.						
Thread	M6	Length 35 mm	6	9640.930	6	9640.930
	M8	Length 35 mm	6	9640.940	6	9640.940
	M10	Length 80 mm	6	9640.960	6	9640.960

¹⁾ Sliding blocks or sliding nuts are additionally required for attachment.

Form 2-4 busbar systems

System components, Maxi-PLS 3200

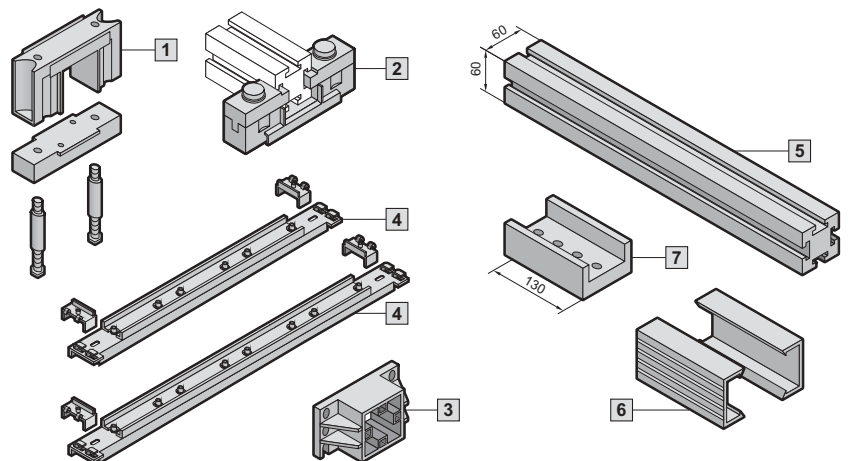

Material:
 Busbar support, end support,
 end cover: PA 6.6
 System attachment:
 Stainless steel
 Cover section: Hard PVC

Note:
 PE/PEN combination/busbars,
 see page 89.

Detailed drawing,
 see page 102.

Maxi-PLS system components			3-pole		4-pole	
			Packs of	Model No. SV	Packs of	Model No. SV
1	Busbar support	3	9650.000	3 + 1	9650.000 9659.000	
2	Busbar support, suitable for top mounting	3	9650.160	3	9650.160	
3	End support	6	9650.010	6 + 2	9650.010 9659.010	
4	System attachment for installing the busbar supports.					
	For application	For enclosure depth mm	Bar centre distance mm			
	In the roof/base section	600	150	2	9650.100	
		800	150	2	9650.080	
	Vertical coupling set	600	150	2	9650.076	
		800	150	2	9659.078	
	Rear section top/bottom	–	150	2	9650.098	
6	Cover section for clip-on mounting on the Maxi-PLS busbars, length 1000 mm.					
7	Longitudinal connector E-Cu for simple baying connection of the Maxi-PLS busbars. Including sliding blocks, bolts, washers and nuts.					
	End cover for clip-on mounting on the end surface of Maxi-PLS busbars.	6	9650.060	6 + 2	9650.060 9659.060	
	Stabiliser to increase short-circuit resistance (I_{cw} up to 124 kA).	4 ²⁾	9650.140	–	–	
5	Maxi-PLS busbars E-Cu (special lengths available on request).					
	Length mm	For enclosure width mm	For application ¹⁾		3200 A	
	491	600	A	1	9650.201	
	525	600	B	1	9650.211	
	599	600	C	1	9650.221	
	691	800	A	1	9650.231	
	725	800	B	1	9650.241	
	799	800	C	1	9650.251	
	891	1000	A	1	9650.261	
	925	1000	B	1	9650.271	
	999	1000	C	1	9650.281	
	1091	1200	A	1	9650.291	
	1125	1200	B	1	9650.301	
	1199	1200	C	1	9650.311	
	2400	–	–	3	9650.360	
	2400	–	–	4	9659.360	

¹⁾ A = Cable connection system with end support
 B = Left-hand or right-hand end enclosure in a switchgear installation
 C = Bayed enclosure with panels bayed on the left and right
²⁾ Modules for two complete stabilisers

Form 2-4 busbar systems

Connection components, Maxi-PLS 3200

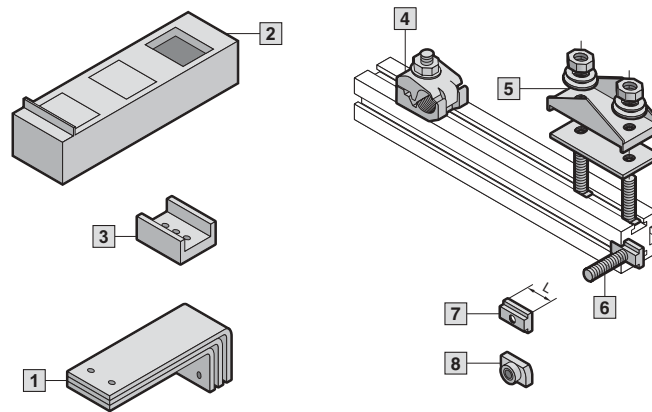

Detailed drawing,
see page 103.

Maxi-PLS connection components			3-pole		4-pole		
			Packs of	Model No. SV	Packs of	Model No. SV	
1 Connection bracket E-Cu Transition from the main busbar system to the connector kits.							
For enclosure depth mm	Width mm	Number of brackets per phase					
600	60	1	1 set	9650.400	–	–	
	60	2	1 set	9650.410	–	–	
	60	3	1 set	9650.420	–	–	
	100	2	1 set	9650.470	–	–	
	100	3	1 set	9650.480	–	–	
800	120	3	1 set	9650.487	–	–	
	60	1	1 set	9659.403	1 set	9659.403 + 9659.404	
	60	2	1 set	9659.413	1 set	9659.413 + 9659.414	
	60	3	1 set	9659.423	1 set	9659.423 + 9659.424	
	100	2	1 set	9659.473	1 set	9659.473 + 9659.474	
	100	3	1 set	9659.483	1 set	9659.483 + 9659.484	
	120	3	1 set	9659.493	1 set	9659.493 + 9659.494	
2 Isolator chassis for isolated routing of the connection brackets. Material: PA 6.6, black. Including assembly parts.							
Bar centre distance mm		For connection bracket width mm					
150		60	1 set	9650.020	1 set	9659.020	
150		100	1 set	9650.030	1 set	9659.030	
3 U contact maker E-Cu for contacting the connection brackets to the Maxi-PLS busbars. Including sliding blocks.							
60 mm width			3	9650.170	3 + 1	9650.170 9659.170	
100 mm width			3	9650.180	3 + 1	9650.180 9659.180	
4 Connection clamp for the connection of round conductors 95 to 300 mm ² (single-wire and multi-wire). Including assembly parts.							
50 mm width			1	9650.325	1	9650.325	
5 Connection plates for the connection of laminated flat copper bars. Including assembly parts.							
2 x 10 x 32 x 1 mm			3	9650.330	3	9650.330	
Maximum clamping area 2 x 10 x 63 x 1 mm			3	9650.340	3	9650.340	
2 x 10 x 100 x 1 mm			3	9650.350	3	9650.350	
6 Terminal stud for connecting cables with ring terminals. Including sliding blocks.							
Thread		M12	Length 32 mm	3	9650.370	3	9650.370
		M16	Length 32 mm	3	9650.380	3	9650.380
7 Sliding blocks for sliding into the Maxi-PLS busbar section at the sides.							
Thread		M10	Length (L) 25 mm	15	9650.980	15	9650.980
		M12	Length (L) 35 mm	15	9650.990	15	9650.990
8 Sliding nuts for retrospective insertion into the Maxi-PLS busbar section.							
M6			15	9650.900	15	9650.900	
Thread		M10	15	9650.910	15	9650.910	
		M12	15	9650.920	15	9650.920	
Threaded bolts for individual connection options ¹⁾ . Including plain washers, spring lock washers and nuts.							
Thread		M6	Length 35 mm	6	9650.930	6	9650.930
		M10	Length 35 mm	6	9650.940	6	9650.940
		M12	Length 80 mm	6	9650.960	6	9650.960

¹⁾ Sliding blocks or sliding nuts are additionally required for attachment.

Form 2-4 busbar systems

Connection components, Maxi-PLS/Flat-PLS

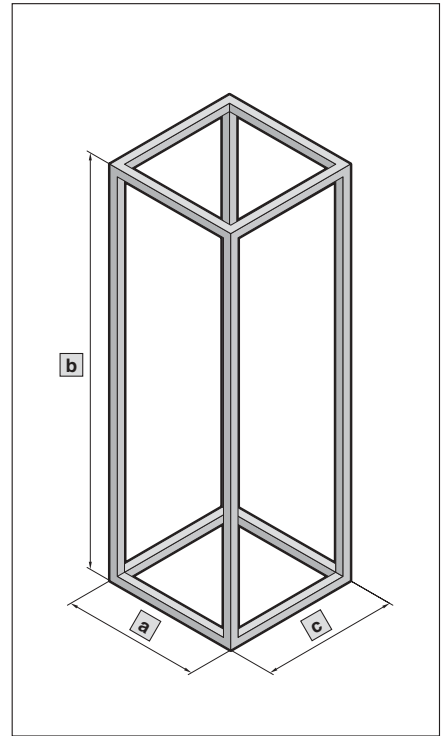
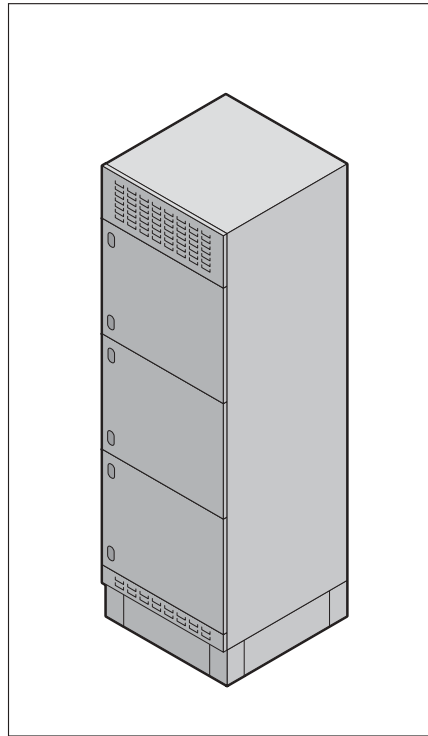

Connector kits

For connecting open power circuit-breakers (ACB) to Flat-PLS busbar systems in SV-TS 8 modular enclosures. Please include the design code of the specification below in the order text for your connector kit. We highly recommend the software Rittal Power Engineering for easier configuration of the connector kits – see Cat. 32, page 1153.

Model No. SV	Design code													
	a	b	c	d	e	f	g	h	i	j	k	l	m	
Top	9676.910													
Bottom	9676.912													

Material:

E-Cu

Note:

Please quote the complete design code on all enquiries and orders.

Enclosure

a	Width	400 <input type="checkbox"/> 4	600 <input type="checkbox"/> 6	800 <input type="checkbox"/> 8	Selection	
	b	Height	1800 <input type="checkbox"/> 8	2000 <input type="checkbox"/> 0	2200 <input type="checkbox"/> 2	Selection
			c	Depth	600 <input type="checkbox"/> 6	800 <input type="checkbox"/> 8

Form 2-4 busbar systems

Connection components, Maxi-PLS/Flat-PLS

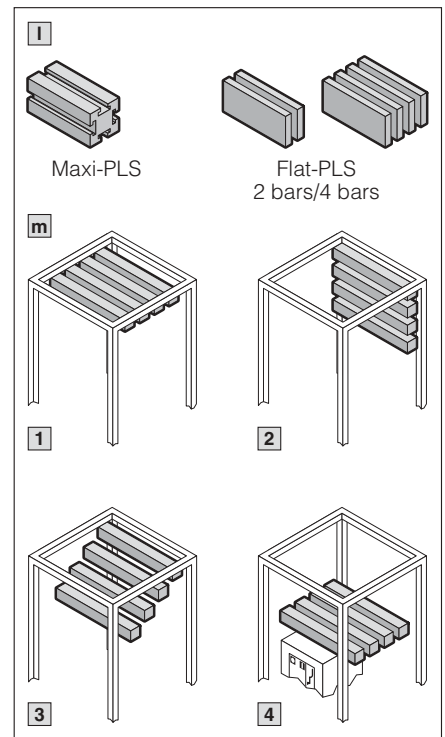
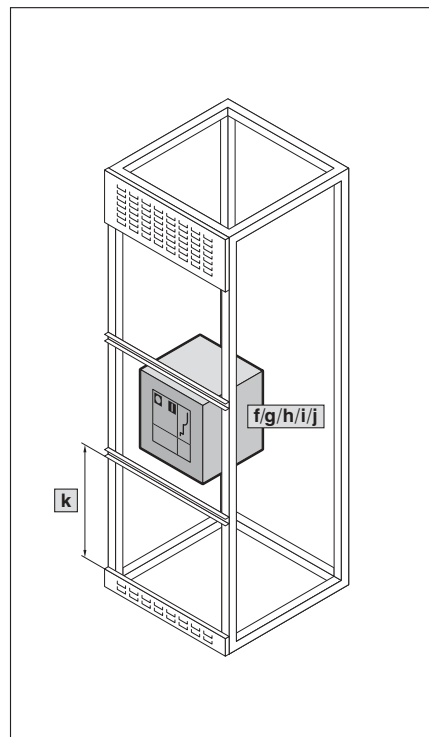
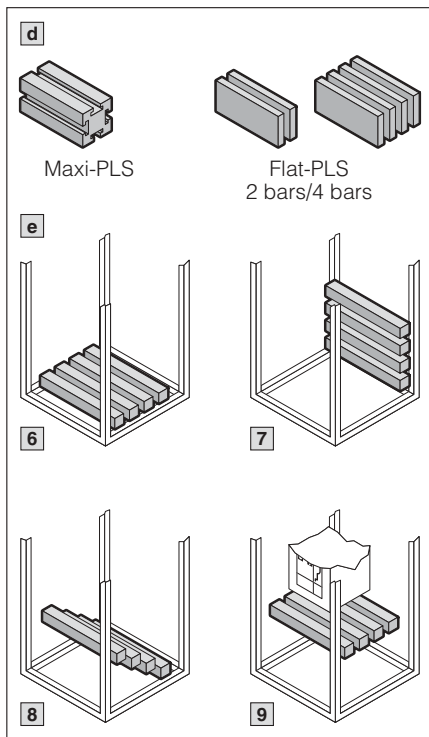

Connector kits

Below the power circuit-breaker

Busbar type			
d	Maxi-PLS	1600	3-pole A
			4-pole B
		2000	3-pole C
		4-pole D	
	3200	3-pole E	Selection <input type="checkbox"/>
		4-pole F	
Flat-PLS	60 2 bars	3-pole G	Selection <input type="checkbox"/>
		4-pole H	
	60 4 bars	3-pole I	
		4-pole J	
	100 2 bars	3-pole K	
		4-pole L	
100 4 bars	3-pole M		
	4-pole N		
Busbar system configuration			
e	in the base section	6	Selection <input type="checkbox"/>
	in the lower rear section	7	
	as cable connection system	8	
	directly underneath the power circuit-breaker	9	

Power circuit-breakers

f	Brand	ABB	A	Selection <input type="checkbox"/>	
		Mitsubishi	J		
		Merlin Gerin	M		
		Siemens/Moeller	S		
		Various	V		
g	Size	1/none	1	Selection <input type="checkbox"/>	
		2	2		
		3	3		
		4	4		
h	Rated current	630 A	A	Selection <input type="checkbox"/>	
		800 A	B		
		1000 A	C		
		1250 A	D		
		1600 A	E		
		2000 A	F		
		2500 A	G		
		3200 A	H		
		4000 A	I		
i	No. of poles/ version	Static	3-pole	3	Selection <input type="checkbox"/>
			4-pole	4	
		Rack-mounted	3-pole	6	
			4-pole	8	
j	Position	Behind the door	H	Selection <input type="checkbox"/>	
		In front of the door (in door cut-out)	V		
k	Compartment height directly underneath the power circuit-breaker	0 mm	0	Selection <input type="checkbox"/>	
		150 mm	1		
		200 mm	2		
		250 mm	3		
		300 mm	4		
		400 mm	5		
		600 mm	6		
		800 mm	7		
1000 mm	8				

Above the power circuit-breaker

Busbar type			
i	Maxi-PLS	1600	3-pole A
			4-pole B
		2000	3-pole C
		4-pole D	
	3200	3-pole E	Selection <input type="checkbox"/>
		4-pole F	
Flat-PLS	60 2 bars	3-pole G	Selection <input type="checkbox"/>
		4-pole H	
	60 4 bars	3-pole I	
		4-pole J	
	100 2 bars	3-pole K	
		4-pole L	
100 4 bars	3-pole M		
	4-pole N		
Busbar system configuration			
m	in the roof section	1	Selection <input type="checkbox"/>
	in the top rear section	2	
	as cable connection system	3	
	directly above the power circuit-breaker	4	

Form 2-4 busbar systems

Flat-PLS



Busbar support Flat-PLS

for flat copper busbars (see below)

For the configuration of busbar systems from flat copper bars. For mounting on a system attachment or directly on the mounting plate. Also suitable for aluminium and copper-plated aluminium bars.

Max. permissible tolerance of bar width (60/100 mm) ± 0.3 mm, bar thickness (10 mm) ± 0.15 mm.

Material:

Polyamide (PA 6.6), 25 % fibreglass-reinforced. Continuous operating temperature max. 130°C. Fire protection corresponding to UL 94-V0.

Colour:

RAL 9005

Short-circuit protection levels:

- Flat-PLS 60
up to 51 kA 1 sec./109 kA peak
- Flat-PLS 100
up to 80 kA 1 sec./176 kA peak

Supply includes:

Assembly parts.

Note:

The internal busbar support insert may be rotated through 90° to allow upright or flat installation of the busbars.

Busbars,

see page 88.



Accessories:

System attachment for Flat-PLS, see page 80.
End cover, see page 82.
Spacer, see page 82.
Filler piece, see page 82.

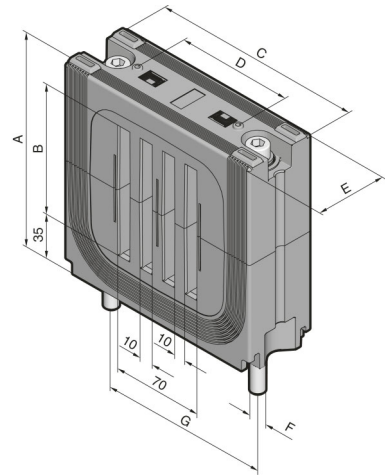

System	For busbars up to	A mm	B mm	C mm	D mm	E mm	F	G mm	Packs of	Model No. SV
1 Flat-PLS 60	4 x 60 x 10 mm	127.5	60	120	70	50	M8	100	1	9676.002 ¹⁾
2 Flat-PLS 100	4 x 100 x 10 mm	162.5	100	165	90	55	M10	125	1	9676.004 ¹⁾

¹⁾ With a bar width of < 60/100 mm the spacer should be used.

When using only 1, 2 or 3 bars, the vacant bar slots should be closed using the filler pieces.



System attachments

for Flat-PLS

For the assembly of 3- or 4-pole busbar systems of flat copper bars.

For mounting on the TS frame or punched section with mounting flange.

Material:

Stainless steel

Supply includes:

Assembly parts.

For busbar support Flat-PLS 60

For application	For enclosure depth mm	Bar centre distance mm	For assembly		Packs of	Model No. SV
			3-pole	4-pole		
In the roof section/ base section	600	125	■	■	2	9674.162
	800	125	■	■	2	9674.182
Vertical coupling set/ Directly underneath the coupling switch	600	125	■	■	2	9674.172
	800	125	■	■	2	9674.192
Rear section ¹⁾	–	125	■	■	2	9674.122
Single-pole assembly, for mounting on the TS 8 frame	–	–	–	–	2	9674.102

For busbar support Flat-PLS 100

For application	For enclosure depth mm	Bar centre distance mm	For assembly		Packs of	Model No. SV
			3-pole	4-pole		
In the roof section/ base section	600	165	■	–	2	9674.164
	800	165	■	■	2	9674.184
Vertical coupling set/ Directly underneath the coupling switch	600	165	■	–	2	9674.174
	800	165	■	■	2	9674.194
Rear section ¹⁾²⁾	–	165	■	■	2	9674.124
Single-pole assembly, for mounting on the TS 8 frame	–	–	–	–	2	9674.104

¹⁾ For mounting between the TS 8 roof frame and TS punched section with mounting flange.

²⁾ In conjunction with form separation, may only be used in 800 mm deep TS enclosures.



Busbar support Flat-PLS

for stabiliser bar (see below)

For the configuration of busbar systems from flat copper bars with increased short-circuit resistance. For mounting on a system attachment or directly on the mounting plate.

Also suitable for aluminium and copper-plated aluminium bars.

Max. permissible tolerance of bar width (60/100 mm) ± 0.3 mm, bar thickness (10 mm) ± 0.15 mm.

Material:

Polyamide (PA 6.6), 25 % fibreglass-reinforced. Continuous operating temperature max. 130°C. Fire protection corresponding to UL 94-V0.

Colour:

RAL 9005

Short-circuit protection levels:

- Flat-PLS 60
up to 75 kA 1 sec./165 kA peak
- Flat-PLS 100
up to 100 kA 1 sec./220 kA peak

Supply includes:

Assembly parts.

Note:

The internal busbar support insert may be rotated through 90° to allow upright or flat installation of the busbars.

Busbars,

see page 88.



Also required:

System attachment for Flat-PLS, see page 80.
Busbar stabiliser bar, see page 81.



Accessories:

End cover, see page 82.
Spacer, see page 82.
Filler piece, see page 82.

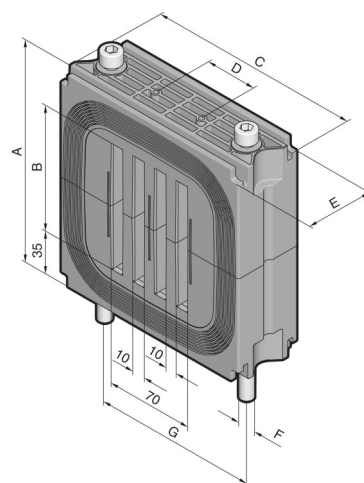

System	For busbars up to	A mm	B mm	C mm	D mm	E mm	F	G mm	Packs of	Model No. SV
Flat-PLS 60	4 x 60 x 10 mm	130	60	120	70	50	M8	100	1	9676.020 ¹⁾
Flat-PLS 100	4 x 100 x 10 mm	170	100	165	90	55	M10	125	1	9676.021 ¹⁾

¹⁾ With a bar width of < 60/100 mm the spacer should be used.

When using only 1, 2 or 3 bars, the vacant bar slots should be closed using the filler pieces.



Busbar stabiliser bars

for busbar support Flat-PLS

For the configuration of busbar systems from flat copper bars with increased short-circuit resistance. For mounting in conjunction with system attachment and Flat-PLS busbar support for stabiliser bar.

Material:

Stainless steel



Also required:

System attachment for Flat-PLS, see page 80.



Accessories:

Busbar claw, see page 83.

For system	For busbar supports	System assembly	Packs of	Model No. SV
Flat-PLS 60	SV 9676.020	3-pole	2	9676.022
		4-pole	2	9676.023
Flat-PLS 100	SV 9676.021	3-pole	2	9676.024
		4-pole	2	9676.025

Form 2-4 busbar systems

Flat-PLS

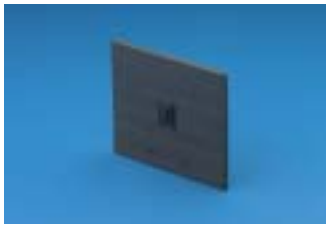

End covers

for busbar support Flat-PLS

Inserted into the Flat-PLS busbar supports for electric shockproof covering of the busbar ends.

Material:

Polyamide (PA 6.6).
Continuous operating temperature max. 130°C.
Fire protection corresponding to UL 94-V0.

Colour:

RAL 9005

For system	For busbar supports		Packs of	Model No. SV
Flat-PLS 60	SV 9676.002	SV 9676.020	2	9676.006
Flat-PLS 100	SV 9676.004	SV 9676.021		



Filler pieces

for busbar support Flat-PLS

To cover open chambers in busbar supports when using only 1, 2 or 3 bars per conductor or when using a busbar support as an end support.

Material:

Polyamide (PA 6.6), 25 % fibreglass-reinforced.
Continuous operating temperature max. 130°C.
Fire protection corresponding to UL 94-V0.

Colour:

RAL 9005

For system	For busbar supports		Packs of	Model No. SV
Flat-PLS 60	SV 9676.002	SV 9676.020	16	9676.008 ¹⁾
Flat-PLS 100	SV 9676.004	SV 9676.021		

¹⁾ Two required per chamber.

When using a busbar support as an end support, eight are required per support.



Spacers

for busbar support Flat-PLS

When using smaller busbar widths, the spacer piece should be inserted into the chambers of the support to compensate for width differences.

Material:

Polyamide (PA 6.6), 25 % fibreglass-reinforced.
Continuous operating temperature max. 130°C.
Fire protection corresponding to UL 94-V0.

Colour:

RAL 9005

For system	E-Cu Dimensions	Required number of spacers per chamber	Packs of	Model No. SV
Flat-PLS 60	40 x 10 mm	2	16	9676.007
	50 x 10 mm	1		
Flat-PLS 100	80 x 10 mm	2		





Busbar claws

for Flat-PLS

For the assembly of busbar systems from flat copper bars with increased short-circuit resistance or for the mechanical stabilisation of busbar stacks.

Material:

Stainless steel.

Accessories: Sheet steel, zinc-plated, passivated

Supply includes:

Assembly parts.



Accessories:

Cover for busbar claw, see page 83.



For system	For busbars up to	Packs of	Model No. SV
Flat-PLS 60	2 x 60 x 10 mm	1	9676.011
	3 x 60 x 10 mm	1	9676.012
	4 x 60 x 10 mm	1	9676.013
Flat-PLS 100	2 x 100 x 10 mm	1	9676.014
	3 x 100 x 10 mm	1	9676.015
	4 x 100 x 10 mm	1	9676.016



Covers

for busbar claws

For shockproof covering of the busbar claws. The cover terminates flush with the cover sections of the Flat-PLS system.

Material:

Polyamide (PA 6.6), 25 % fibreglass-reinforced.

Continuous operating temperature max. 130°C.

Fire protection corresponding to UL 94-V0.

Colour:

RAL 7035



Accessories:

Cover section, see page 83.



For system	No. of bars per conductor	For busbar claws		Packs of	Model No. SV
Flat-PLS 60/ Flat-PLS 100	2	SV 9676.011	SV 9676.014	8	9676.046
	3	SV 9676.012	SV 9676.015	8	9676.047
	4	SV 9676.013	SV 9676.016	8	9676.048

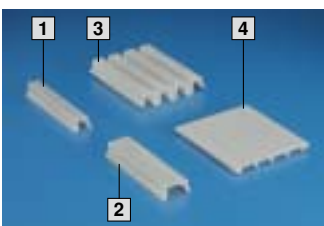

Cover sections

for Flat-PLS

For electric shockproof covering of the Flat-PLS busbar system and connector kits for open power circuit-breakers. The cover sections may also be used outside of Flat-PLS for covering standard, commercially available flat copper bars. Edge cover sections should always be combined with side cover sections when assembling the cover.

Material:

Thermally modified hard PVC.

Continuous operating temperature max. 95°C.

Fire protection corresponding to UL 94-V0.

Colour:

RAL 7035



	For system	No. of bars per conductor	For busbar width mm	Length mm	Packs of	Model No. SV
1	Edge cover section for bar systems with no space between the bars	1	–	1000	10	9676.041
		2	–	1000	10	9676.042
		3	–	1000	10	9676.043
2	Edge cover section for bar systems with 10 mm space between the bars	2	–	1000	10	9676.052
		3	–	1000	10	9676.053
		4	–	1000	10	9676.054
3	Side cover section for bar systems, to match the edge cover sections	–	60	1000	10	9676.056
		–	80	1000	10	9676.058
		–	100	1000	10	9676.059

Form 2-4 busbar systems

Flat-PLS



Direct connection terminals for Flat-PLS

For direct connection of round conductors 95 – 300 mm² (multi-strand or sector-shaped). The mounting accessories supplied loose may be used to mount the connection terminal on the Flat-PLS busbar system without the need for drilling.

Material:
Brass alloy,
nickel-plated surface finish

Supply includes:
Assembly parts.

For system	For busbar width mm	Packs of	Model No. SV
Flat-PLS 60	60	1	9676.731
Flat-PLS 100	100	1	9676.733



Connection plates with bolts M12/16 for Flat-PLS

For connecting ring terminals to a Flat-PLS busbar system with 2 – 4 bars per conductor. The mounting accessories supplied loose may be used to mount the connection terminal on a Flat-PLS busbar system without the need for drilling.

Material:
E-Cu, nickel-plated

Supply includes:
Assembly parts.

For system	For busbar width mm	Terminal studs	Packs of	Model No. SV
Flat-PLS 60	60	M12	1	9676.701
Flat-PLS 60	60	M16	1	9676.705
Flat-PLS 100	100	M12	1	9676.703
Flat-PLS 100	100	M16	1	9676.707



Connection plates with bolts M10 for Flat-PLS

For connecting ring terminals to a Flat-PLS busbar system with 2 – 4 bars per conductor. The straight-through screws and the mounting accessories supplied loose may be used to mount the connection terminal on a Flat-PLS busbar system without the need for drilling.

Material:
E-Cu, nickel-plated

Supply includes:
Assembly parts.

For system	For busbar width mm	Terminal studs	Packs of	Model No. SV
Flat-PLS 60	60	M10	1	9676.711
Flat-PLS 60	60	2 x M10	1	9676.715
Flat-PLS 100	100	M10	1	9676.713
Flat-PLS 100	100	2 x M10	1	9676.717



Connection plates for laminated copper bars

for Flat-PLS

For connecting laminated copper bars 10 x 40 x 1.0 mm (Flexibar) to a Flat-PLS busbar system with 2 – 4 bars per conductor. The mounting accessories supplied loose may be used to mount the copper bar on a Flat-PLS busbar system without the need for drilling.

Material:

E-Cu, nickel-plated

Supply includes:

Assembly parts.

Laminated copper bars, see page 95.

For system	For busbar width mm	For laminated copper bars up to	Packs of	Model No. SV
Flat-PLS 60	60	10 x 40 x 1.0 mm	1	9676.721
Flat-PLS 100	100	10 x 40 x 1.0 mm	1	9676.723



Longitudinal connectors for Flat-PLS

For connecting Flat-PLS busbar systems, no drilling required.

Material:

E-Cu

Supply includes:

Assembly parts.

Note:

Nickel-plated version of the longitudinal connector for connecting aluminium bars available on request.



For system	For busbar width mm	No. of strands per conductor	Packs of	Model No. SV
Flat-PLS 60	60	2	1	9676.626
	60	3 or 4	1	9676.646
Flat-PLS 100	80	2	1	9676.628
	80	3 or 4	1	9676.648
	100	2	1	9676.620
	100	3 or 4	1	9676.640



Contact makers for Flat-PLS

For connecting connection brackets and connector kits of flat copper bars to Flat-PLS busbar systems; no drilling required.

Material:

E-Cu

Supply includes:

Assembly parts.

Note:

Nickel-plated version of the contact maker for connecting aluminium bars available on request.



For system	For busbar width mm	No. of strands per conductor	Packs of	Model No. SV
Flat-PLS 60	60	2	1	9676.526
	60	3 or 4	1	9676.546
Flat-PLS 100	80	2	1	9676.528
	80	3 or 4	1	9676.548
	100	2	1	9676.520
	100	3 or 4	1	9676.540

Form 2-4 busbar systems

Flat-PLS



1



2

Connection bracket for Flat-PLS

For connecting connection brackets and connector kits of flat copper bars to Flat-PLS busbar systems; no drilling required.

Material:
E-Cu

Supply includes:
Assembly parts.

! Also required:

Contact maker, see page 85.
Connector kit for Flat-PLS, see page 87.

Note:

Contact maker only required when connecting connector kits of open power circuit-breakers to a Flat-PLS main busbar system in the roof section.

	For system Flat-PLS	For conductor	No. of strands per conductor	Bar width of connection bracket	Packs of	Model No. SV	Packs of	Model No. SV	
					For enclosure depth 600 mm		For enclosure depth 800 mm		
1	for connecting connector kits of open power circuit-breakers to a Flat-PLS 60 main busbar system in the roof section	L1, L2, L3	1	60	1 set	9676.201	1 set	9676.221	
		N			1 set	9676.202	1 set	9676.222	
		L1, L2, L3	2		1 set	9676.203	1 set	9676.223	
		N			1 set	9676.204	1 set	9676.224	
		L1, L2, L3	3		1 set	9676.205	1 set	9676.225	
		N			1 set	9676.206	1 set	9676.226	
		L1, L2, L3	2	100	1 set	9676.213	1 set	9676.233	
		N			1 set	9676.214	1 set	9676.234	
		L1, L2, L3	3		1 set	9676.215	1 set	9676.235	
		N			1 set	9676.216	1 set	9676.236	
		L1, L2, L3	3		120	1 set	9676.217	1 set	9676.237
		N				1 set	9676.218	1 set	9676.238
		L1, L2, L3	1	60		1 set	9676.301	1 set	9676.321
		N				–	–	1 set	9676.322
		L1, L2, L3	2			1 set	9676.303	1 set	9676.323
		N				–	–	1 set	9676.324
		L1, L2, L3	3		1 set	9676.305	1 set	9676.325	
		N			–	–	1 set	9676.326	
L1, L2, L3	2	100	1 set	9676.313	1 set	9676.333			
N			–	–	1 set	9676.334			
L1, L2, L3	3		1 set	9676.315	1 set	9676.335			
N			–	–	1 set	9676.336			
L1, L2, L3	3		120	1 set	9676.317	1 set	9676.337		
N				–	–	1 set	9676.338		
2	for connecting connector kits of open power circuit-breakers to a Flat-PLS 60 cable connection bar system	L1, L2, L3		1	60	1 set	9676.241	1 set	9676.261
		N				1 set	9676.242	1 set	9676.262
		L1, L2, L3		2		1 set	9676.243	1 set	9676.263
		N				1 set	9676.244	1 set	9676.264
		L1, L2, L3	3	1 set		9676.245	1 set	9676.265	
		N		1 set		9676.246	1 set	9676.266	
		L1, L2, L3	2	100	1 set	9676.253	1 set	9676.273	
		N			1 set	9676.254	1 set	9676.274	
		L1, L2, L3	3		1 set	9676.255	1 set	9676.275	
		N			1 set	9676.256	1 set	9676.276	
		L1, L2, L3	3		120	1 set	9676.257	1 set	9676.277
		N				1 set	9676.258	1 set	9676.278
		L1, L2, L3	1	60		1 set	9676.341	1 set	9676.361
		N				–	–	1 set	9676.362
		L1, L2, L3	2			1 set	9676.343	1 set	9676.363
		N				–	–	1 set	9676.364
		L1, L2, L3	3		1 set	9676.345	1 set	9676.365	
		N			–	–	1 set	9676.366	
		L1, L2, L3	2	100	1 set	9676.353	1 set	9676.373	
		N			–	–	1 set	9676.374	
		L1, L2, L3	3		1 set	9676.355	1 set	9676.375	
		N			–	–	1 set	9676.376	
		L1, L2, L3	3		120	1 set	9676.357	1 set	9676.377
		N				–	–	1 set	9676.378



Connector kits for Flat-PLS

For connecting open power circuit-breakers (ACB) to Flat-PLS busbar systems in SV-TS 8 modular enclosures. Please include the design code of the specification shown on page 78 in the order text for your required connector kit. We highly recommend the Rittal Power Engineering software for easier configuration of the connector kits – see Cat. 32, page 1153.

Note:

Model No. design code, see page 78.

Material:
E-Cu

Supply includes:
Assembly parts.



Screw connections M12 for special connection bracket versions

For connecting special connection brackets and a connector kit. May be used for 3- and 4-pole connector kits.

Supply includes:

8 nuts and
16 washers.

Note:

For a bar width of 120 mm, 2 packs are required per connector kit.

For system	No. of brackets per phase	Packs of	Model No. SV
Flat-PLS 60/ Flat-PLS 100	1	8	9676.961
	2	8	9676.962
	3	8	9676.963

Form 2-4 busbar systems

Busbars and accessories

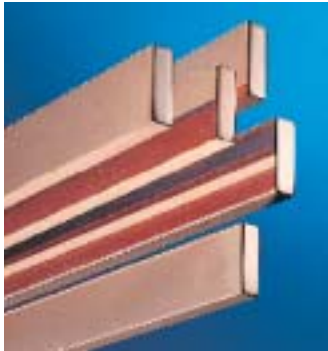

Busbars

made from E-Cu
To DIN EN 13 601.
Length: 2400 mm/bar.

Dimensions mm	Weight/bar kg	Packs of	Model No. SV
12 x 5	1.28	6	3580.000
15 x 5	1.60	6	3581.000
20 x 5	2.14	6	3582.000
25 x 5	2.67	6	3583.000
30 x 5	3.20	6	3584.000
12 x 10	2.56	6	3580.100
15 x 10	3.20	6	3581.100
20 x 10	4.27	6	3585.000
30 x 10	6.41	6	3586.000
40 x 10	8.55	3	3587.000
50 x 10	10.68	3	3588.000
60 x 10	12.82	3	3589.000
80 x 10	17.09	3	3590.000
100 x 10	21.38	3	3590.010



Busbar cover section

Contact hazard protection via full encapsulation of the busbars. May be cut to required length.

Material:
Thermally modified hard PVC.
Continuous operating temperature max. 91°C.
Fire protection corresponding to UL 94-V0.

For busbars mm	Width (B) mm	Packs of	Model No. SV
12 x 5 – 30 x 10	40.6	10 @ 1 m	3092.000
40 – 60 x 10	70.6	10 @ 1 m	3085.000

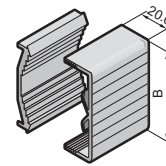

1

2

Busbar support

1- and 2-pole

Material:
Polyamide (PA 6.6), 25 % fibreglass-reinforced.
Continuous operating temperature max. 130°C.
Fire protection corresponding to UL 94-V0.

Colour:
RAL 7035

Version	1 1-pole	2 2-pole
Bar centre distance	–	60 mm
For busbars E-Cu	12 x 5 – 30 x 10 mm	12 x 5 – 30 x 10 mm
Tightening torque		
● Assembly screw M5 x 16	3 – 5 Nm	3 – 5 Nm
● Cover attachment	1 – 3 Nm	1 – 3 Nm
Packs of	4	4
Model No. SV	9340.030¹⁾	9340.040²⁾

¹⁾ PEN/N/PE support
²⁾ N/PE support



3

1

2

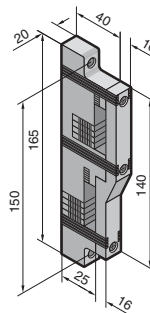
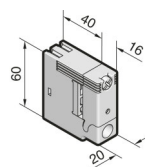

+ Accessories:

3 Additional attachment for SV 9340.030

Optional anti-twist guard for SV 9340.030. Facilitates support alignment with horizontal or vertical mounting.

Packs of	Model No. SV
4	9340.035

Supply includes:
8 connection pins.



1 and 3



1



2

1 Busbars

made from E-Cu

Suitable for

- Direct installation in enclosures
- Busbar support
 - SV 9340.000/.010, see page 56
 - SV 9340.004, see page 64
 - SV 9342.014, see page 66
 - SV 3052.000, see Cat. 32, page 391
 - SV 3073.000, see Cat. 32, page 387
- PE/PEN combinations in conjunction with combination angle and baying bracket.

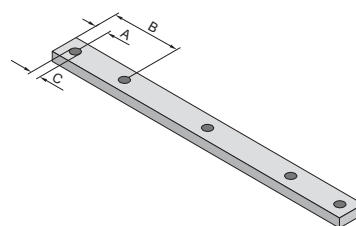

For enclosure width mm	Packs of	Length mm	30 x 5 mm	30 x 10 mm	Length mm	40 x 10 mm	80 x 10 mm
			Model No. SV	Model No. SV		Model No. SV	Model No. SV
300	2	265	9661.335	9661.330	292	9661.030	9661.130
400	2	365	9661.345	9661.340	392	9661.040	9661.140
600	2	565	9661.365	9661.360	592	9661.060	9661.160
800	2	765	9661.385	9661.380	792	9661.080	9661.180
1000	2	965	9661.305	9661.300	992	9661.000	9661.100
1200	2	1165	9661.325	9661.320	1192	9661.020	9661.120
A mm			15	15		20	20
B mm			–	–		158.5	158.5
C mm			Ø 11	Ø 11		Ø 14	Ø 14

Accessories

2 Baying bracket E-Cu	4	95	9661.355	9661.350	–	–	–
		–	–	–	88	9661.050	9661.150

PE/PEN combination angle

for PE/PEN combinations

The PE/PEN combination, comprised of busbars, combination angles and baying brackets, facilitates type-tested assembly to IEC 60 439-1.

The pre-manufactured combination angles and baying brackets, and the busbars customised to the individual enclosure width, facilitate inexpensive, time-saving assembly.

Material:

E-Cu

Supply includes:

Assembly parts.

Technical specifications:

Tested short-circuit resistance

PE/PEN combination

- 30 x 5 mm:
I_{cw} 18 kA, 1 sec.
- PE/PEN combination 30 x 10 mm:
I_{cw} 30 kA, 1 sec.
- PE/PEN combination 40/80 x 10 mm:
I_{cw} 30 kA, 1 sec.;
I_{cw} 48 kA, 1 sec. (when mounting on bare profile frame)



Combination angle for	Packs of	For busbars mm			
		30 x 5	30 x 10	40 x 10	80 x 10
Insert Form 2-4	4	9661.235	9661.230	9661.240	9661.240¹⁾
Other applications	4	9661.235	9661.230	9661.200	9661.200¹⁾

¹⁾ E-Cu 40 x 10 mm

Base isolators

For configuring busbar systems with any given bar centre distances and for assembling PE or PEN bars.

Material:

Duroplastic polyester (UP resin).

Continuous operating temperature: Max. 135°C.

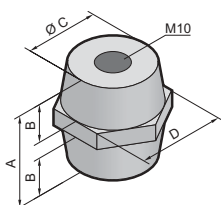

Rated operating voltage	1 kV	1 kV
Tensile strength	12 kN	13 kN
Torsional strength	75 Nm	90 Nm
Bending strength	6 kN	6 kN
Tightening torque	40 Nm	40 Nm
A mm	40	50
B mm	15	19
Ø C mm	32	42
D mm	SW 36	SW 50
Packs of	6	6
Model No. SV	3031.000	3032.000

Form 2-4 busbar systems

Accessories



Busbar connectors

For connecting busbars, no drilling required.

Material:

SV 9350.075

Top part: St 37, nickel-plated surface finish
Base: E-Cu

SV 9320.020/SV 9320.030

Top part: Sheet steel, zinc-plated, passivated
Contact plate: E-Cu, silver-plated



For busbars mm	Application of		Tightening torque	Packs of	Model No. SV
	Single connection	Bayed connection ¹⁾			
12 x 5 – 15 x 10	1	–	5 Nm/15 Nm ²⁾	3	9350.075
20 x 5 – 30 x 10	2	–	20 Nm	3	9320.020
	–	3	20 Nm	3	9320.030

¹⁾ From enclosure to enclosure

²⁾ Hex socket

– Screw M8 = 5 Nm

– Grub screw M8 = 15 Nm

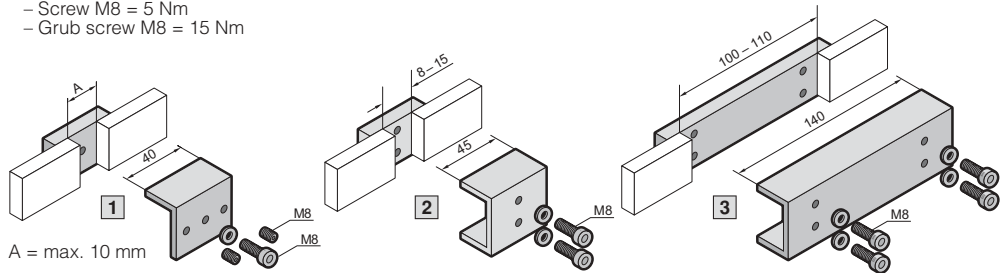

PLS busbar connectors

For connecting the PLS special busbars; no drilling required.

Material:

E-Cu, nickel-plated

For	Packs of	Model No. SV for system	
		PLS 800	PLS 1600
A Single connection	3	3504.000	3514.000
B Baying connection ¹⁾	3	3505.000	3515.000
Tightening torque		10 – 15 Nm	15 – 20 Nm

¹⁾ From enclosure to enclosure (TS 8)

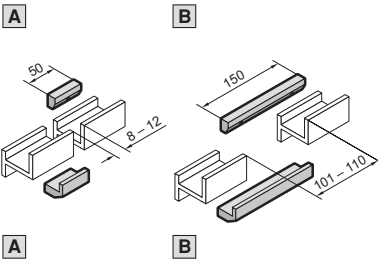

PLS expansion connectors

For thermal and mechanical compensation during connection of PLS special busbars from enclosure to enclosure (TS 8).

Material:

E-Cu

Packs of	Model No. SV for system	
	A PLS 800	B PLS 1600
3	9320.060	9320.070

Also required

PLS busbar connectors ¹⁾	3504.000	3514.000

¹⁾ Two busbar connectors are needed to fit one expansion connector.

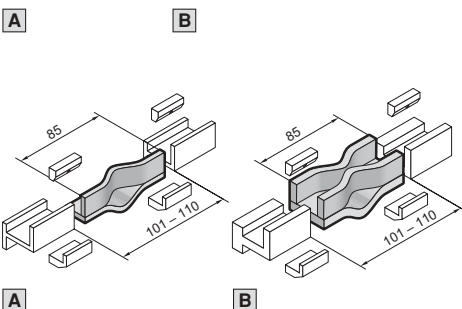

Note:

With a temperature increase of 30 K, the busbars will expand in length by around 0.5 mm/m. Consequently, the use of an expansion connector is recommended for busbar systems with lengths in excess of 3 m.



T-connector kits

for Maxi-PLS/RiLine60 bar systems

For connecting horizontal Maxi-PLS main busbar systems to vertical RiLine60 busbar distributor systems in the modular outgoing feeder panel.

Material:

E-Cu

Supply includes:

Assembly parts.



Also required:

Distributor busbars, see page 92.

Main busbar system	Busbar distributor system	Packs of	Model No. SV	
			3-pole	4-pole
In the roof section/base section		Behind the compartment		
Maxi-PLS 1600/2000	Cu 30 x 10/5 mm	1 set	9675.303	9675.304
Maxi-PLS 3200	Cu 30 x 10/5 mm	1 set	9675.313	9675.314
Maxi-PLS 1600/2000	PLS 1600	1 set	9675.306	9675.307
Maxi-PLS 3200	PLS 1600	1 set	9675.316	9675.317
In the roof section/base section		In the compartment (indoors)		
Maxi-PLS 1600/2000	Cu 30 x 10/5 mm	1 set	9675.323	9675.324
Maxi-PLS 3200	Cu 30 x 10/5 mm	1 set	9675.333	9675.334
Maxi-PLS 1600/2000	PLS 1600	1 set	9675.326	9675.327
Maxi-PLS 3200	PLS 1600	1 set	9675.336	9675.337
In the rear section top/bottom		Behind the compartment		
Maxi-PLS 1600/2000	Cu 30 x 10/5 mm	1 set	9675.343	9675.344
Maxi-PLS 3200	Cu 30 x 10/5 mm	1 set	9675.353	9675.354
Maxi-PLS 1600/2000	PLS 1600	1 set	9675.346	9675.347
Maxi-PLS 3200	PLS 1600	1 set	9675.356	9675.357
In the rear section top/bottom		In the compartment (indoors)		
Maxi-PLS 1600/2000	Cu 30 x 10/5 mm	1 set	9675.363	9675.364
Maxi-PLS 3200	Cu 30 x 10/5 mm	1 set	9675.373	9675.374
Maxi-PLS 1600/2000	PLS 1600	1 set	9675.366	9675.367
Maxi-PLS 3200	PLS 1600	1 set	9675.376	9675.377



T-connector kits

for Rittal RiLine60 busbar systems

For connecting horizontal RiLine60 main busbar systems to vertical RiLine60 busbar distributor systems.

Material:

E-Cu

Supply includes:

Assembly parts.



Also required:

Distributor busbars, see page 92.

Main busbar system	Busbar distributor system	Packs of	Model No. SV	
			3-pole	4-pole
Behind the compartment				
PLS 1600	Cu 30 x 10/5 mm	1 set	9675.130	9675.140
Cu 30 x 10/5 mm	Cu 30 x 10/5 mm	1 set	9675.133	9675.143
PLS 1600	PLS 1600	1 set	9675.136	9675.146
Inside the compartment				
PLS 1600/Cu 30 x 10/5 mm	Cu 30 x 10/5 mm	1 set	9675.153	9675.163
PLS 1600	PLS 1600	1 set	9675.156	9675.166

Form 2-4 busbar systems

Accessories



Distributor busbars

Material:
E-Cu

Prepared for the connection of T-connector kits, see page 91. The lengths are adapted for applications in TS 8 enclosures.

For main busbar system with RiLine60 and busbar distributor system behind the compartment	For busbar distributor system in the compartment (indoors)	Packs of	Version			
			Cu 30 x 10 mm		PLS 1600	
For enclosure height mm			Length mm	Model No. SV	Length mm	Model No. SV
1800	–	1	1210	9675.218	1150	9675.238
2000	–	1	1410	9675.210	1350	9675.230
2200	1800 ¹⁾	1	1610	9675.212	1550	9675.232
–	2000 ¹⁾	1	1810	9675.220	1750	9675.240
–	2200 ¹⁾	1	2010	9675.222	1950	9675.242

¹⁾ Also suitable as a vertical busbar for PE/PEN/N.



System attachments

for RiLine60 main busbar system

System attachment with M5 and M6 threaded holes in a 50 mm pitch for the rear assembly of a RiLine60 main busbar system up to 1600 A. For locating into the TS frame.

Material:

Sheet steel, zinc-plated, passivated

Supply includes:

Assembly parts.

Note:

RiLine60 busbar systems, see page 55 – 70.

For enclosure width mm	Width mm	Height mm	Packs of	Model No. SV
300	238.5	362	1	9674.003
400	338.5	362	1	9674.004
600	538.5	362	1	9674.006
800	738.5	362	1	9674.008



Terminal studs

for special versions of connector kits and connection brackets

Special bolt for attaching a connector kit or connection bracket with and without U contact maker to a Maxi-PLS busbar section.

May be used for 3- and 4-pole connector kits.

Supply includes:

8 nuts and 8 washers.

Note:

For a connection kit bar width of 120 mm, 2 packs are required per connector kit.

No. of bars per phase when using		Packs of	For Maxi-PLS 1600/2000		For Maxi-PLS 3200	
with U contact maker	without U contact maker ¹⁾		Length mm	Model No. SV	Length mm	Model No. SV
–	1	8	35	9676.971	40	9676.981
–	2	8	45	9676.972	50	9676.982
1	3	8	55	9676.973	60	9676.983
2	–	8	70	9676.976	70	9676.986
3	–	8	80	9676.977	80	9676.987

¹⁾Sliding blocks additionally required.



Screw connections M12

for special connection bracket versions

For connecting special connection brackets and a connector kit.

May be used for 3- and 4-pole connector kits.

Supply includes:

8 nuts and 16 washers.

Note:

For a bar width of 120 mm, 2 packs are required per connector kit.

For Maxi-PLS	No. of bars per phase	Packs of	Model No. SV
1600/2000/3200	1	8	9676.961
	2	8	9676.962
	3	8	9676.963



Copper castors

for Maxi-PLS and flat copper bars

For use as a universal spacer.

Material:

E-Cu

Diameter (D) mm	Length mm	Packs of	Model No. SV
30	20	4	9676.503
40	20	4	9676.504
50	20	4	9676.505

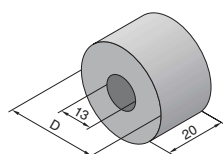

Form 2-4 busbar systems

Accessories

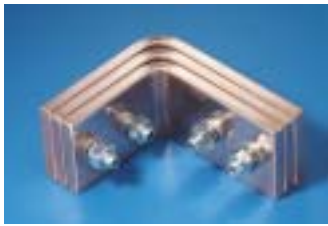

Corner bracket

E-Cu

- For connecting horizontal Maxi-PLS busbar systems in the roof/base section to vertical busbar systems.
- For 90° connection of two Maxi-PLS busbars in the rear area.
- May be used for individual installation.

Material:

E-Cu

Supply includes:

Bracket, threaded bolts, nuts, washers.

Note:

No. of corner brackets required for applications

- 3-pole = 3
- 4-pole = 4

For Maxi-PLS	Packs of	3-/4-pole			Page
		1600	2000	3200	
No. of brackets per phase		2 x 60 x 10 mm	3 x 60 x 10 mm	3 x 80 x 10 mm	
Model No. SV	1	9640.705	9640.700	9650.700	
Also required					
Sliding blocks	15	9640.980 ¹⁾	9640.980 ¹⁾	9650.990 ¹⁾	75/77

¹⁾Quantity required per corner bracket: 4.



Connector kits

for busbar riser

For connecting horizontal Maxi-PLS busbar systems in the rear section to vertical busbar systems.

Material:

E-Cu

Supply includes:

Assembly parts.

Note:

Busbars for Maxi-PLS 1600/2000, see page 74.

Busbars for Maxi-PLS 3200, see page 76.

For Maxi-PLS	For enclosure depth mm	No. of brackets per phase	Packs of	Model No. SV	
				for 3-pole	for 4-pole
1600	600/800	2	1 set	9660.318	9660.318 + 9660.319
2000	600/800	3	1 set	9660.313	9660.313 + 9660.314
3200	600	3	1 set	9660.363	–
3200	800	3	1 set	9660.368	9660.368 + 9660.369



Coupling set mounting kit

for SV-TS 8 busbar enclosure

The mounting kit is used as a base support for a vertical Maxi-PLS bar system.

Material:

Sheet steel, zinc-plated, passivated

Supply includes:

Support plate and punched sections with mounting flanges, assembly parts.

For enclosure width mm	For enclosure depth mm	Packs of	Model No. SV
200	600	1 set	9674.196
200	800	1 set	9674.198



Also required:

End support, see page 74/76.



Form 2-4 busbar systems

Laminated copper bars and accessories

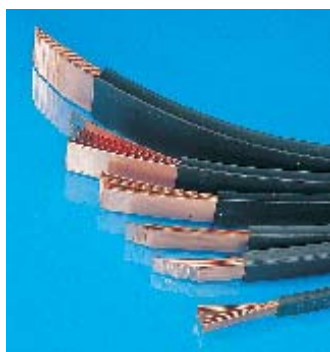

Laminated copper bars Rittal Flexibar "S"

Length: 2000 mm/bar.

Material:

Cu lamina

- High-purity electrolyte copper F20

Insulation

- High-strength vinyl compound
- Expansion 370 %
- Temperature range: -30°C to +105°C
- Flame retardant version to UL 94-V0
- Dielectric strength: 20 kV/mm

Note:

Short-circuit protection diagram, see page 101.

Configuration ¹⁾ mm	I _n for 50 K ²⁾	I _n for 30 K ²⁾	I _n for 10 K ²⁾	Packs of	Model No. SV
8 x 6.0 x 0.5	165 A	125 A	–	1	3565.010
6 x 9.0 x 0.8	250 A	220 A	120 A	1	3565.000
6 x 13.0 x 0.5	200 A	150 A	110 A	1	3566.000
4 x 15.5 x 0.8	300 A	210 A	140 A	1	3567.000
6 x 15.5 x 0.8	350 A	290 A	170 A	1	3568.000
10 x 15.5 x 0.8	450 A	350 A	190 A	1	3569.000
5 x 20.0 x 1.0	400 A	300 A	180 A	1	3570.000
5 x 24.0 x 1.0	450 A	370 A	230 A	1	3571.000
10 x 24.0 x 1.0	800 A	600 A	340 A	1	3572.000
5 x 32.0 x 1.0	550 A	470 A	280 A	1	3573.000
10 x 32.0 x 1.0	1000 A	800 A	460 A	1	3574.000
5 x 40.0 x 1.0	800 A	600 A	340 A	1	3575.000
10 x 40.0 x 1.0	1200 A	950 A	500 A	1	3576.000
5 x 50.0 x 1.0	900 A	700 A	400 A	1	3577.000
10 x 50.0 x 1.0	1400 A	1000 A	600 A	1	3578.000
10 x 63.0 x 1.0	1600 A	1240 A	715 A	1	3579.000

¹⁾ Number of lamina x lamina width x lamina thickness

²⁾ The conductor temperature of the laminated copper bar is derived by adding the ambient temperature and the temperature increase together.

Example:

SV 3565.000 carrying 220 A, i.e. the temperature increases by 30 K. At an ambient temperature of 35°C, this produces a resultant conductor temperature of 35°C + 30 K = 65°C.



Universal support

For the attachment of laminated copper bars from 20 x 5 to 63 x 10 mm.

Material:

Fibreglass-reinforced, thermoplastic polyester (PBT).

Fire protection corresponding to UL 94-V0.

Supply includes:

Screws and "U" nuts for mounting on PS/TS mounting rails.

Packs of	Model No. SV
3	3079.000

Note:

Short-circuit protection diagram, see page 101.

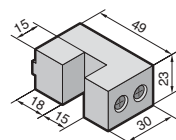

Universal holder

For the attachment of multi-stacked laminated copper bars from 40 x 5 to 100 x 10 mm.

Material:

Fibreglass-reinforced, thermoplastic polyester (PBT).

Fire protection corresponding to UL 94-V0.

Supply includes:

Screws and sliding nuts for attachment on C rails.

Packs of	Model No. SV
3 sets	3079.010



Accessories:

C rails 30/15, see Catalogue 32, page 999

Form 2-4 busbar systems

RiLine60 accessories



Spacers

for RiLine60 busbar supports (flat busbar system)

For adapting 12 x 5 and 12 x 10 mm size busbars.

For busbar supports

- SV 9340.000/.010 (3-pole), see page 56.
- SV 9340.004 (4-pole), see page 64.

Packs of	Model No. SV
12	9340.090



Insert strip

for circuit-breaker component adaptors

To extend the construction width from 140 mm to 190 mm.

Width: 25 mm.

Material:

ABS

Colour:

RAL 7035

Note:

4 pieces (1 set) are needed to widen a component adaptor.

For	Packs of	Model No. SV
SV 9342.700 SV 9342.710	4 (1 set)	9342.720



Support rail 35 x 15 mm

for component adaptors

Width 72 mm.

Material:

Sheet steel, zinc-plated, passivated

Supply includes:

Assembly screws and side end brackets.

For	Packs of	Model No. SV
SV 9342.400 SV 9342.410	5	9320.120



Sliding blocks

for circuit-breaker component adaptors

For additional power circuit breakers with more than two attachment points.

For	With threaded insert	Packs of	Model No. SV
SV 9342.500/.510 SV 9342.540/.550	M3/M4	6	9342.560
SV 9342.600/.610	M4/M5	6	9342.640



SV 9342.570

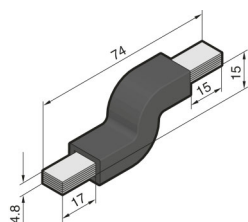

SV 9342.660 – SV 9342.690

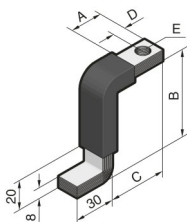

SV 9342.770 – SV 9342.790

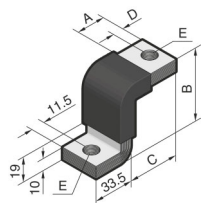

Connection bracket

for circuit-breaker component adaptors

Pre-assembled, laminated flat copper for connecting standard, commercially available moulded case circuit-breakers (MCCB).

Material:

Electrolyte copper F20

Insulation:

Vinyl compound.
Temperature resistant up to 105°C.
Fire protection corresponding to UL 94-V0.

Dimensions ¹⁾ mm	For circuit-breaker component adaptor	For connecting moulded case circuit-breakers (MCCB), make (model)	Packs of ²⁾	Model No. SV
6 x 9 x 0.8	SV 9342.500/.510 SV 9342.540/.550	Moeller (NZM1)	3	9342.570
10 x 15.5 x 0.8	SV 9342.600/.610	ABB (T3), GE (FE)	3	9342.660
		Merlin Gerin (NS100/160/250), Telemecanique (GV7)	3	9342.670
		ABB (S3), Moeller (NZM2), Siemens (VL250)	3	9342.680
		Siemens (VL160X, VL160)	3	9342.690
10 x 32.0 x 1.0	SV 9342.700/.710	ABB (T5)	3	9342.770
		ABB (S5), Merlin Gerin (NS400/630)	3	9342.780
		Moeller (NZM3)	3	9342.790

¹⁾ Number of lamina x lamina width x lamina thickness

²⁾ 3 = 1 set

Model No. SV	A mm	B mm	C mm	D mm	E mm
9342.660	26	65	43	9	Ø 10
9342.670	19	66	36	10	Ø 10
9342.680	23	71	40	9	Ø 10
9342.690	23	67	40	11	Ø 7
9342.770	26	51	43	9	Ø 12
9342.780	29	57	46	12	Ø 12
9342.790	28	62	38	14	Ø 12

Form 2-4 technical information

Short-circuit resistance diagrams RiLine60

Busbar support

up to 800 A, 3-pole Page 56

Model No. SV 9340.000/SV 9340.010

60 mm bar centre distance,
for busbars 15 x 5 – 30 x 10 mm.

Rated operating voltage: up to 690 V AC
Rated insulation voltage: 1000 V AC
Rated surge voltage: 8 kV
Overvoltage category: IV
Level of contamination: 3
Rated frequency: 50/60 Hz

Test implemented:

- Rated surge current resistance I_{pk} (see diagram)
- Rated short-time current resistance I_{cw}

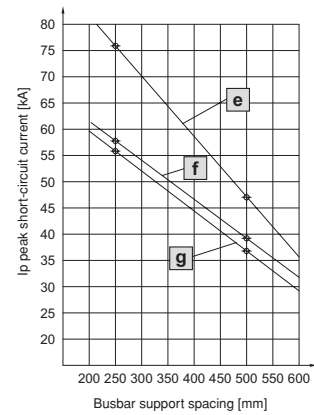
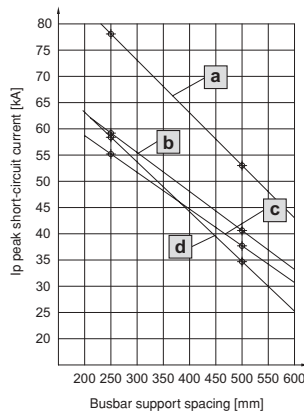

Busbar mm	l mm	I_{cw} kA
30 x 10	250	37.6
30 x 5	250	25.4
20 x 10	250	29.0

Busbar mm	Curve
30 x 10	a
20 x 10	b
25 x 5	c
15 x 5	d

Busbar mm	Curve
30 x 5	e
20 x 5	f
15 x 10	g

PLS busbar supports

up to 800 A/1600 A, 3-pole Page 58

Model No. SV 9341.000/SV 9342.000

60 mm bar centre distance,
for Mini-PLS special busbars.

Rated operating voltage: up to 690 V AC
Rated insulation voltage: 1000 V AC
Rated surge voltage: 8 kV
Overvoltage category: IV
Level of contamination: 3
Rated frequency: 50/60 Hz

Test implemented:

- Rated surge current resistance I_{pk} (see diagram)
- Rated short-time current resistance I_{cw}

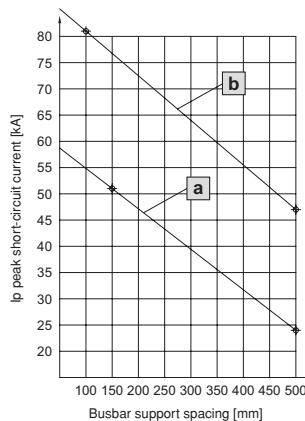

Busbar mm	l mm	I_{cw} kA
PLS 800 A	150	25.9
PLS 1600 A	150	37.5

Busbar mm	Curve
PLS 800 A	a
PLS 1600 A	b

Busbar support

up to 800 A, 4-pole Page 64/66

Model No. SV 9340.004/SV 9342.014

60 mm bar centre distance,
for 30 x 10 mm busbars.

Rated operating voltage:

up to 690 V AC

Rated insulation voltage:

1000 V AC

Rated surge voltage: 8 kV

Overtoltage category: IV

Level of contamination: 3

Rated frequency: 50/60 Hz

Test implemented:

- Rated surge current resistance I_{pk}
(see diagram)
- Rated short-time current resistance I_{cw}

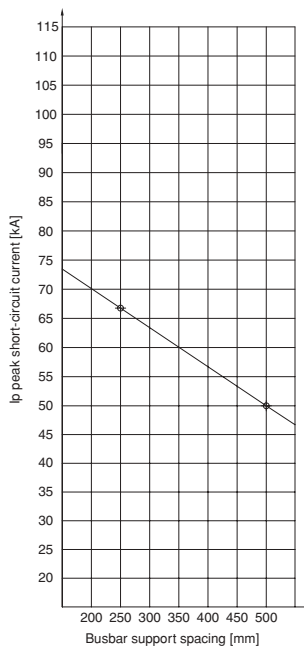

Busbar mm	l mm	I_{cw} kA
30 x 10	250	29
	500	23

PLS busbar supports

up to 1600 A, 4-pole Page 66

Model No. SV 9342.004

60 mm bar centre distance,
for PLS special busbar 1600 A.

Rated operating voltage:

up to 690 V AC

Rated insulation voltage:

1000 V AC

Rated surge voltage: 8 kV

Overtoltage category: IV

Level of contamination: 3

Rated frequency: 50/60 Hz

Test implemented:

- Rated surge current resistance I_{pk}
(see diagram)
- Rated short-time current resistance I_{cw}

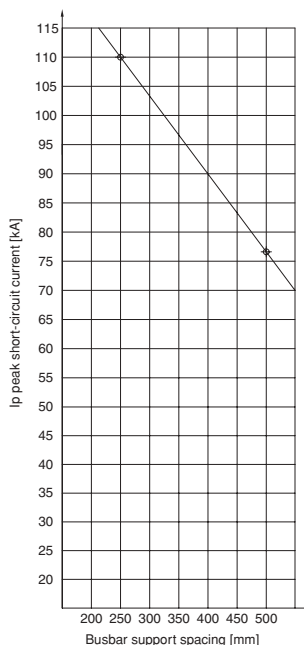

Busbar mm	l mm	I_{cw} kA
PLS 1600 A	250	53
	500	38

Form 2-4 technical information

Rated currents of busbars E-Cu (DIN 43 671)

DIN 43 671 specifies the constant currents for busbars at an ambient temperature of 35°C and an average busbar temperature of 65°C. With the aid of a correction factor (k_2), the continuous currents specified in the following table may be adjusted to alternative operating temperatures.

For safe operation with thermal reserve, it is advisable to limit the busbar temperature to a maximum of 85°C. However, the decisive factor is the lowest permissible continuous temperature of the components which directly contact the busbar system (fuse bases, outgoing cables etc.). The ambient air temperature of the busbars or busbar system should not exceed 40°C; an average of 35°C maximum is recommended.

For the continuous temperatures specified in the table, an emission level of 0.4 applies, equivalent to an oxidating copper bar. In modern busbar systems – built into enclosures with a protection category of IP 54 and above – a more favourable emission level can be assumed. The lower emission level facilitates an additional increase in continuous currents compared with the figures in DIN 43 671, irrespective of the specified air and busbar temperature. Experience has shown an increase in the continuous current of 6 – 10 % compared with the table figures for uncoated copper bars, and 60 % for surface-oxidised copper bars.

Example:

For a Cu bar 30 x 10 mm (E-Cu F30), DIN 43 671 specifies a constant current of $I_{N65} = 573$ A.

The correction factor diagram for square cross-sections indicates a correction factor $k_2 = 1.29$ at an air temperature of 35°C and a busbar temperature of 85°C. Thanks to the favourable emission level, the continuous current is increased by a further 6 – 10 %. In this example, a mean value of 8 % is used. Compared with the table figure from DIN 43 671, the Rittal rated current specification for a Cu bar 30 x 10 mm is:

$$I_{N85} = I_{N65} \cdot k_2 + 8\% \\ = 573 \text{ A} \cdot 1.29 \cdot 1.08 \\ I_{N85} = 800 \text{ A}$$

Continuous currents for busbars

Made from E-Cu with square cross-section in indoor locations at 35°C air temperature and 65°C bar temperature, vertical position or horizontal position of the bar width.

Width x thickness mm	Cross-section mm ²	Weight ¹⁾	Material ²⁾	Continuous current in A			
				AC current up to 60 Hz		DC current + AC current 16 Hz	
				Bare bar	Coated bar	Bare bar	Coated bar
12 x 2	23.5	0.209		108	123	108	123
15 x 2	29.5	0.262		128	148	128	148
15 x 3	44.5	0.396		162	187	162	187
20 x 2	39.5	0.351		162	189	162	189
20 x 3	59.5	0.529		204	237	204	237
20 x 5	99.1	0.882		274	319	274	320
20 x 10	199.0	1.770		427	497	428	499
25 x 3	74.5	0.663		245	287	245	287
25 x 5	124.0	1.110		327	384	327	384
30 x 3	89.5	0.796		285	337	286	337
30 x 5	149.0	1.330		379	447	380	448
30 x 10	299.0	2.660	E-Cu F30	573	676	579	683
40 x 3	119.0	1.060		366	435	367	436
40 x 5	199.0	1.770		482	573	484	576
40 x 10	399.0	3.550		715	850	728	865
50 x 5	249.0	2.220		583	697	588	703
50 x 10	499.0	4.440		852	1020	875	1050
60 x 5	299.0	2.660		688	826	696	836
60 x 10	599.0	5.330		985	1180	1020	1230
80 x 5	399.0	3.550		885	1070	902	1090
80 x 10	799.0	7.110		1240	1500	1310	1590

¹⁾ Calculated with a density of 8.9 kg/dm³

²⁾ Reference basis for the continuous current levels (figures taken from DIN 43 671)

Rittal PLS current load

According to DIN 43 671, the correction factor k_2 (correction diagram) is used to correct the basic current with reference to the existing temperatures of the ambient air and the busbar. In accordance with DIN 43 671, the load figures of the Rittal PLS special bars have been determined on the basis of measurement trials, as follows:

PLS special busbars	Rated current AC 50/60 Hz	
	for 35/75°C	for 35/65°C (basic value)
E-Cu 800 A	800 A	684 A
E-Cu 1600 A	1600 A	1368 A

Correction factor diagram to DIN 43 671

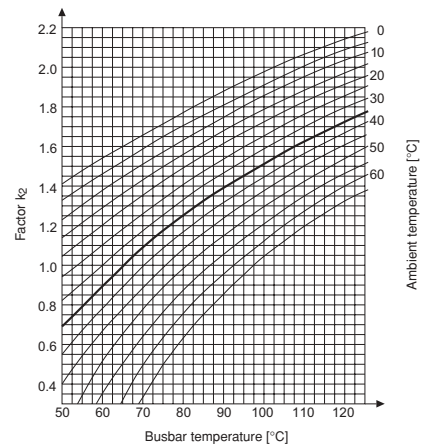

Correction factor diagram for PLS

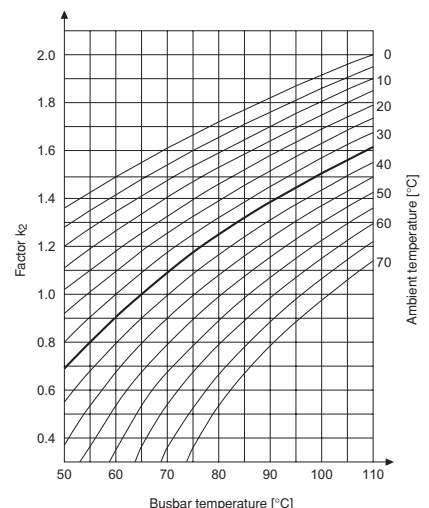



Laminated copper bars Rittal Flexibar "S"

Page 95

Configuration ¹⁾ mm	I _n for 50 K ²⁾	I _n for 30 K ²⁾	I _n for 10 K ²⁾	Curve (short-circuit resistance)	Installation type	Model No. SV
8 x 6.0 x 0.5	165 A	125 A	–	–	–	3565.010
6 x 9.0 x 0.8	250 A	220 A	120 A	–	–	3565.000
6 x 13.0 x 0.5	200 A	150 A	110 A	–	–	3566.000
4 x 15.5 x 0.8	300 A	210 A	140 A	–	–	3567.000
6 x 15.5 x 0.8	350 A	290 A	170 A	a	1	3568.000
10 x 15.5 x 0.8	450 A	350 A	190 A	a	1	3569.000
5 x 20.0 x 1.0	400 A	300 A	180 A	a	1	3570.000
5 x 24.0 x 1.0	450 A	370 A	230 A	a	1	3571.000
10 x 24.0 x 1.0	800 A	600 A	340 A	b	1	3572.000
5 x 32.0 x 1.0	550 A	470 A	280 A	b	2/3	3573.000
10 x 32.0 x 1.0	1000 A	800 A	460 A	c	2/3	3574.000
5 x 40.0 x 1.0	800 A	600 A	340 A	b	2/3	3575.000
10 x 40.0 x 1.0	1200 A	950 A	500 A	c	2/3	3576.000
5 x 50.0 x 1.0	900 A	700 A	400 A	b	2/3	3577.000
10 x 50.0 x 1.0	1400 A	1000 A	600 A	c	2/3	3578.000
10 x 63.0 x 1.0	1600 A	1240 A	715 A	d	2/3	3579.000

¹⁾ Number of lamina x lamina width x lamina thickness

²⁾ The conductor temperature of the laminated copper bar is derived by adding the ambient temperature and the temperature increase together.

Example:

SV 3565.000 carrying 220 A, i.e. the temperature increases by 30 K. At an ambient temperature of 35°C, this produces a resultant conductor temperature of 35°C + 30 K = 65°C.

Short-circuit resistance diagram

Basis of test:
VDE 0660, part 500/IEC 60 439-1.
Test implemented:
Dynamic short-circuit resistance
to IEC 60 439-1.

The dimensions for the support spacing (l) and for the centre-to-centre spacing (a) must be within the specified min./max. limits. The quotients of l/a can be used to determine the permissible short-circuit current I_p by using curves a to d. The prescribed installation type must be taken into account.

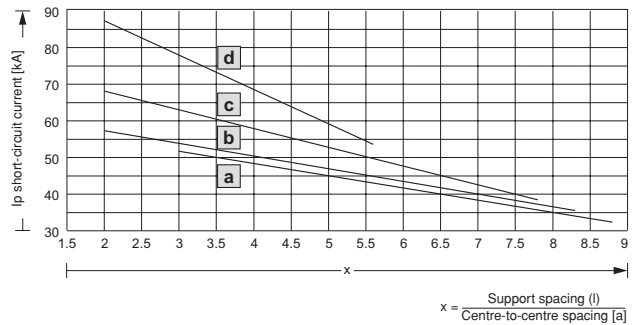

Curve	Support spacing (l) mm		Centre-to-centre spacing (a) mm	
	min.	max.	min.	max.
a	150	300	34	60
b	150	350	42	85
c	200	400	51	85
d	200	450	81	100

Type of assembly with universal support SV 3079.000

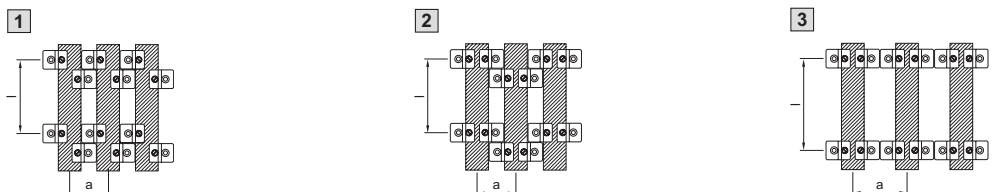

Form 2-4 technical information

Maxi-PLS system components

Maxi-PLS 1600/2000

Page 74

Busbar supports
Model No. (SV 9640.000/SV 9649.000)

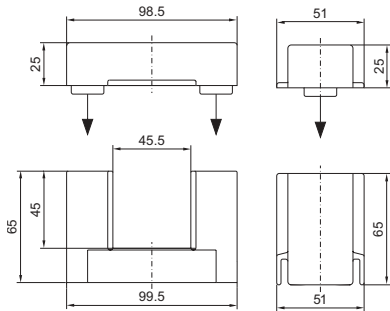

Busbar support, suitable for top mounting
Model No. SV 9640.160

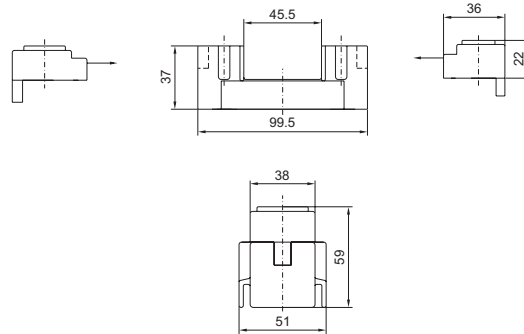

End supports
Model No. (SV 9640.010, SV 9649.010)

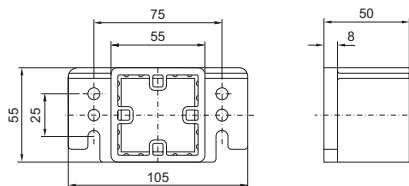

Maxi-PLS 3200

Page 76

Busbar supports
Model No. (SV 9650.000/SV 9659.000)

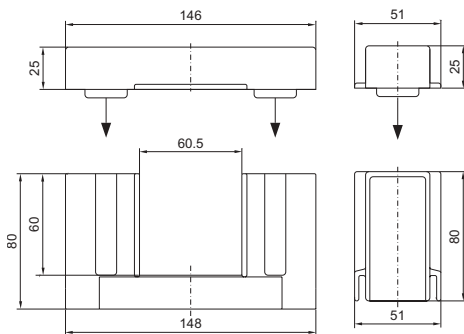

Busbar support, suitable for top mounting
Model No. SV 9650.160

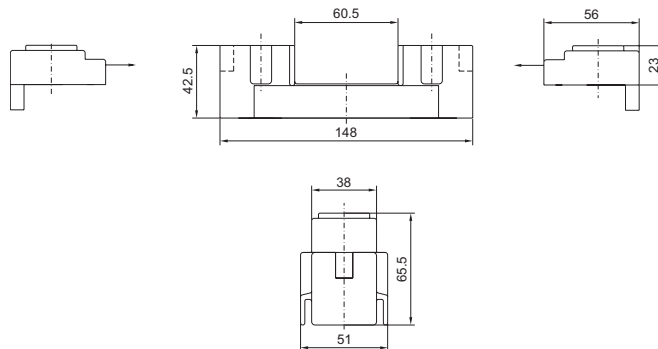

End supports
Model No. (SV 9650.010, SV 9659.010)

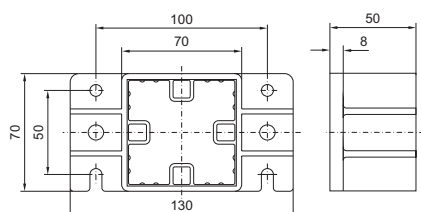

Stabiliser
Model No. SV 9650.140

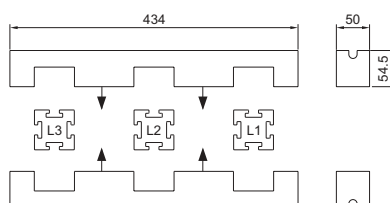

Maxi-PLS 1600/2000

Page 75

Maxi-PLS 3200

Page 77

Isolator chassis

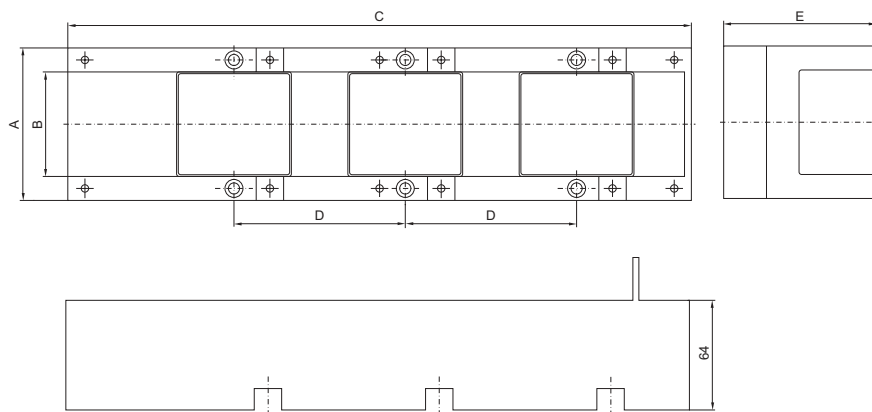

Model No. SV	A	B	C	D	E
9640.020	89	61	346	100	89
9650.020	89	61	479	150	94
9650.030	129	101	479	150	94

Connection clamp
Model No.
SV 9640.325
SV 9650.325

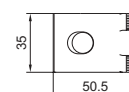
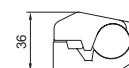

Connection plates

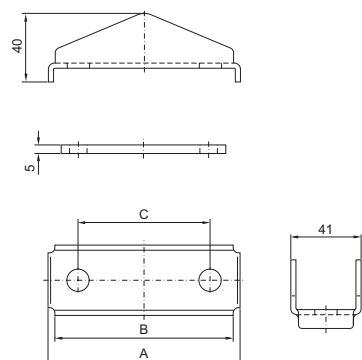

Model No. SV	Size	A	B	C	T-head screws	Tightening torque
9640.330	1	81	73	46	M10	20 Nm
9640.340	2	112	104	77	M10	25 Nm
9640.350	3	149	141	114	M10	30 Nm
9650.330	1	81	73	46	M12	25 Nm
9650.340	2	112	104	77	M12	30 Nm
9650.350	3	149	141	114	M12	35 Nm

Terminal studs
(2000 A)

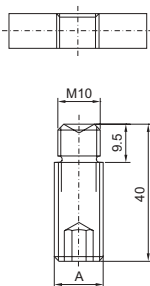

Terminal studs
(3200 A)

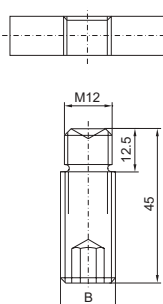

Model No. SV	A	B
9640.370	M12	-
9640.380	M16	-
9650.370	-	M12
9650.380	-	M16

Sliding nuts
(2000 A)

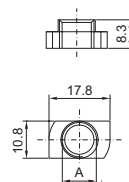

Sliding nuts
(3200 A)

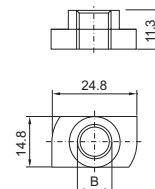

Model No. SV	A	B
9640.900	M6	-
9640.910	M8	-
9640.920	M10	-
9650.900	-	M6
9650.910	-	M10
9650.920	-	M12

Form 2-4 technical information

Dimensions SV-TS 8 enclosures

SV-TS 8 modular enclosures

Page 26 – 28

Cross-sections

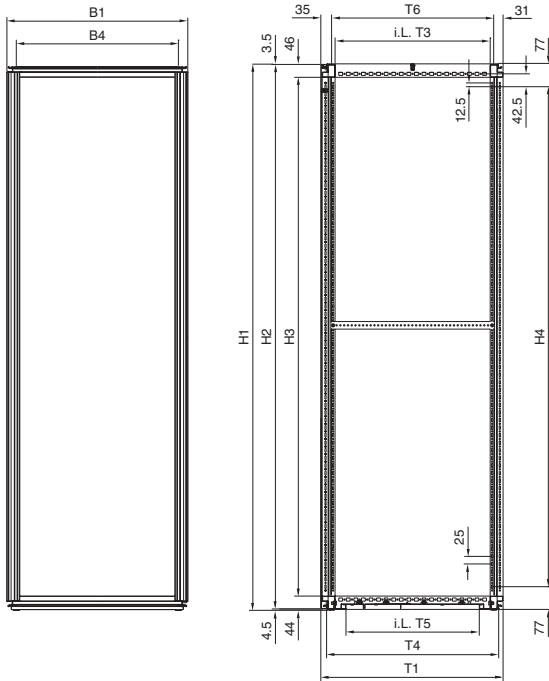

B = Width
T = Depth
i.L. = Clearance width

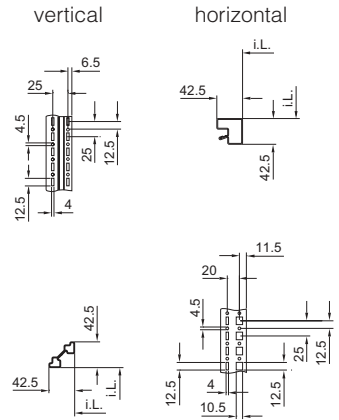

Model No. SV	B1 mm	B2 mm	B3 mm	B4 mm	H1 mm	H2 mm	H3 mm	H4 mm	T1 mm	T2 mm	T3 mm	T4 mm	T5 mm	T6 mm
9670.406	397	312	275	335	2005	1997	1912	1850	601.5	475	512	568	440	535
9670.408	397	312	275	335	2005	1997	1912	1850	801.5	675	712	768	640	735
9670.426	397	312	275	335	2205	2197	2112	2050	601.5	475	512	568	440	535
9670.428	397	312	275	335	2205	2197	2112	2050	801.5	675	712	768	640	735
9670.486	397	312	275	335	1805	1797	1712	1650	601.5	475	512	568	440	535
9670.606	597	512	475	535	2005	1997	1912	1850	601.5	475	512	568	440	535
9670.608	597	512	475	535	2005	1997	1912	1850	801.5	675	712	768	640	735
9670.626	597	512	475	535	2205	2197	2112	2050	601.5	475	512	568	440	535
9670.628	597	512	475	535	2205	2197	2112	2050	801.5	675	712	768	640	735
9670.686	597	512	475	535	1805	1797	1712	1650	601.5	475	512	568	440	535
9670.806	797	712	675	735	2005	1997	1912	1850	601.5	475	512	568	440	535
9670.808	797	712	675	735	2005	1997	1912	1850	801.5	675	712	768	640	735
9670.826	797	712	675	735	2205	2197	2112	2050	601.5	475	512	568	440	535
9670.828	797	712	675	735	2205	2197	2112	2050	801.5	675	712	768	640	735
9670.886	797	712	675	735	1805	1797	1712	1650	601.5	475	512	568	440	535

SV-TS 8 cable chamber enclosures

Page 29 – 31

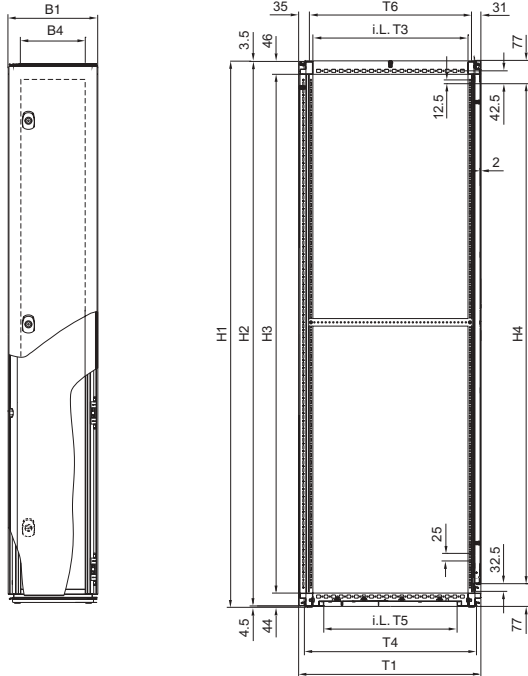

B = Width
T = Depth
i.L. = Clearance width

Cross-sections

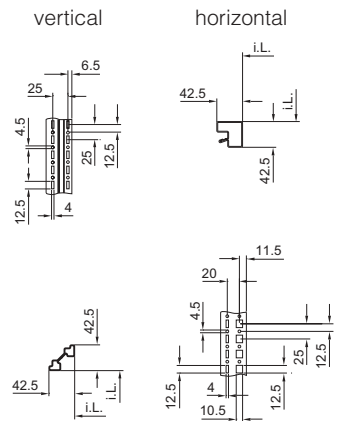

Model No. SV	B1 mm	B2 mm	B3 mm	B4 mm	H1 mm	H2 mm	H3 mm	H4 mm	T1 mm	T2 mm	T3 mm	T4 mm	T5 mm	T6 mm
9670.316	297	212	175	235	2005	1997	1912	1850	605	475	512	568	440	535
9670.318	297	212	175	235	2005	1997	1912	1850	805	675	712	768	640	735
9670.336	297	212	175	235	2205	2197	2112	2050	605	475	512	568	440	535
9670.338	297	212	175	235	2205	2197	2112	2050	805	675	712	768	640	735
9670.396	297	212	175	235	1805	1797	1712	1650	605	475	512	568	440	535
9670.416	397	312	275	335	2005	1997	1912	1850	605	475	512	568	440	535
9670.418	397	312	275	335	2005	1997	1912	1850	805	675	712	768	640	735
9670.436	397	312	275	335	2205	2197	2112	2050	605	475	512	568	440	535
9670.438	397	312	275	335	2205	2197	2112	2050	805	675	712	768	640	735
9670.496	397	312	275	335	1805	1797	1712	1650	605	475	512	568	440	535
9670.616	597	512	475	535	2005	1997	1912	1850	605	475	512	568	440	535
9670.618	597	512	475	535	2005	1997	1912	1850	805	675	712	768	640	735
9670.636	597	512	475	535	2205	2197	2112	2050	605	475	512	568	440	535
9670.638	597	512	475	535	2205	2197	2112	2050	805	675	712	768	640	735
9670.696	597	512	475	535	1805	1797	1712	1650	605	475	512	568	440	535

Form 2-4 technical information

Dimensions SV-TS 8 enclosures

SV-TS 8 busbar enclosures

Page 32

Cross-sections

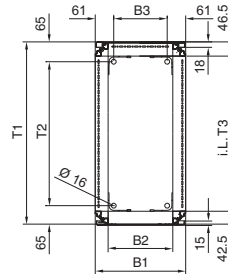
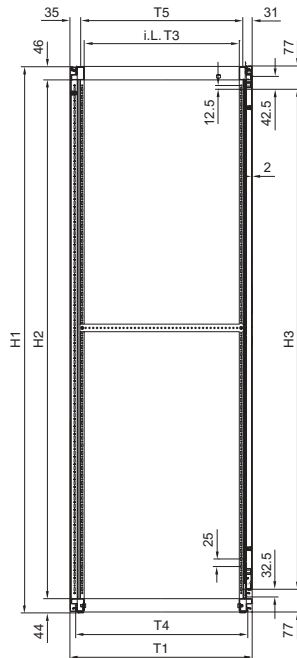
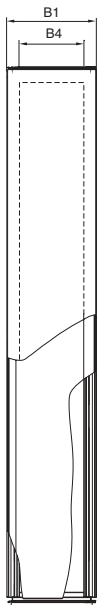

vertical

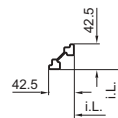
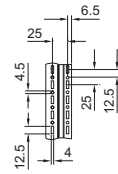

B = Width
T = Depth
i.L. = Clearance width

Model No. SV	B1 mm	B2 mm	B3 mm	B4 mm	H1 mm	H2 mm	H3 mm	T1 mm	T2 mm	T3 mm	T4 mm	T5 mm
9670.206	197	112	75	75	1997	1912	1850	605	475	512	561	535
9670.208	197	112	75	75	1997	1912	1850	805	675	712	761	735
9670.226	197	112	75	75	2197	2112	2050	605	475	512	561	535
9670.228	197	112	75	75	2197	2112	2050	805	675	712	761	735

SV-TS 8 enclosures

for open and compact power circuit-breakers (ACB + MCCB)

Enclosures					
Mechanical characteristics	Dimensions	Enclosure width	400/600/800 mm ³⁾		
		Enclosure height	1800/2000/2200 mm ³⁾		
		Enclosure depth	600/800 mm ³⁾		
	Protection rating	Pitch pattern	25 mm		
	Design		Max. IP 54		
			1 – 4		EN 60 529
Surface protection/ material	Enclosure frame	Dipcoat-primed			
	Panels (roof plate, rear panel)	Dipcoat-primed, powder-coated in RAL 7035 on the outside			
	System attachment	Stainless steel			
	System rails and punched sections with mounting flanges	Sheet steel, zinc-plated, passivated			
Operating and ambient conditions	Ambient temperature	Short-term peak	+40°C		
		Maximum on a 24 h average	+35°C		
		Low	-5°C		
	Atmospheric conditions	Normal climatic stress			
		Relative humidity	50 % at 40°C		EN 60 439-1
		Operation up to 1000 m above sea level			

Maxi-PLS busbar system			Maxi-PLS 1600	Maxi-PLS 2000	Maxi-PLS 3200	
Electrical characteristics	Rated voltage	Rated insulation voltage U_i	1000 V			EN 60 439-1
		Rated operating voltage U_e	690 V			
		Rated surge voltage resistance U_{imp}	8 kV			
		Overtoltage category	IV			
		Level of contamination	3			
		Rated frequency	50 Hz			
	Rated current (primary busbar)	Rated operating current $I_e^{4)}$	1400 A	1800 A	2800 A	IP 54
			1600 A	2000 A	3000 A	IP 2X ¹⁾
			1800 A	2500 A	4000 A	IP 2X ²⁾
		Rated surge current resistance I_{pk}	110 kA		165 kA	EN 60 439-1
Rated short-time current resistance I_{cw}	50 kA		75 kA			
Testing under accidental arc conditions	Permissible uninfluenced short-circuit current	50 kA		70 kA	EN 61 641	
	Test voltage	420 V				
	Permissible arc duration	0.3 sec.				
Mechanical characteristics	Busbar	Material	E-Cu, bare			
		External dimensions (cross-section)	45 x 45 mm (1000 mm ²)	45 x 45 mm (1380 mm ²)	60 x 60 mm (2700 mm ²)	

RiLine60 busbar system			E-Cu 30 x 10 mm	PLS 1600	
Electrical characteristics	Rated voltage	Rated insulation voltage U_i	1000 V		EN 60 439-1
		Rated operating voltage U_e	690 V		
		Rated surge voltage resistance U_{imp}	8 kV		
		Overtoltage category	IV		
		Level of contamination	3		
		Rated frequency	50 Hz		
	Rated current (primary busbar)	Rated operating current $I_e^{4)}$	800 A	1150 A	IP 54
			860 A	1300 A	IP 43
			1000 A ⁵⁾	1600 A ²⁾	IP 2X
		Rated surge current resistance I_{pk}	68 kA	110 kA	EN 60 439-1
Rated short-time current resistance I_{cw}	32 kA, 1 sec.	50 kA, 1 sec./50 kA, 3 sec.			
Testing under accidental arc conditions	Permissible uninfluenced short-circuit current	30 kA	50 kA	EN 61 641	
	Test voltage	690 V			
	Permissible arc duration	0.3 sec.			
Mechanical characteristics	Busbar	Material	E-Cu, bare		
		Version (cross-section)	30 x 10 mm (300 mm ²)	PLS 1600 (900 mm ²)	

1) Using outlet filter SK 3326.207 and roof plate IP 2X.

2) Using fan-and-filter unit SK 3327.107 (700 m³/h) and roof plate IP 2X.

3) Other sizes available on request.

4) Other rated currents for different protection categories on request.

5) Using fan-and-filter unit SK 3325.107 (230 m³/h) and roof plate IP 2X.

Form 2-4 technical information

System data

SV-TS 8 enclosures

for coupling sets

Enclosures				
Mechanical characteristics	Dimensions	Enclosure width	600/800/1000 mm ³⁾	
		Enclosure height	2000/2200 mm ³⁾	
	Enclosure depth	600/800 mm ³⁾		
	Pitch pattern	25 mm		
	Protection rating	Max. IP 54		EN 60 529
Surface protection/ material	Design	Enclosure frame	Dipcoat-primed	
		Panels (roof plate, rear panel)	Dipcoat-primed, powder-coated in RAL 7035 on the outside	
		System attachment	Stainless steel	
		System rails and punched sections with mounting flanges	Sheet steel, zinc-plated, passivated	
Operating and ambient conditions	Ambient temperature	Short-term peak	+40°C	
		Maximum on a 24 h average	+35°C	
		Low	-5°C	
	Atmospheric conditions	Normal climatic stress		
		Relative humidity	50 % at 40°C	
		Operation up to 1000 m above sea level		EN 60 439-1

Maxi-PLS busbar system			Maxi-PLS 1600	Maxi-PLS 2000	Maxi-PLS 3200	
Electrical characteristics	Rated voltage	Rated insulation voltage U_i	1000 V			EN 60 439-1
		Rated operating voltage U_e	690 V			
		Rated surge voltage resistance U_{imp}	8 kV			
		Overtoltage category	IV			
		Level of contamination	3			
		Rated frequency	50 Hz			
	Rated current (primary busbar)	Rated operating current $I_e^{4)}$	1400 A	1800 A	2800 A	For IP 54
			1600 A	2000 A	3000 A	For IP 2X ¹⁾
			1800 A	2500 A	4000 A	For IP 2X ²⁾
		Rated surge current resistance I_{pk}	110 kA		165 kA	EN 60 439-1
Rated short-time current resistance I_{cw}	50 kA		75 kA			
Testing under accidental arc conditions	Permissible uninfluenced short-circuit current	50 kA		70 kA	EN 61 641	
	Test voltage	420 V				
	Permissible arc duration	0.3 sec.				
Mechanical characteristics	Busbar	Material	E-Cu, bare			
		External dimensions (cross-section)	45 x 45 mm (1000 mm ²)	45 x 45 mm (1380 mm ²)	60 x 60 mm (2700 mm ²)	

RiLine60 busbar system			E-Cu 30 x 10 mm	PLS 1600	
Electrical characteristics	Rated voltage	Rated insulation voltage U_i	1000 V		EN 60 439-1
		Rated operating voltage U_e	690 V		
		Rated surge voltage resistance U_{imp}	8 kV		
		Overtoltage category	IV		
		Level of contamination	3		
		Rated frequency	50 Hz		
	Rated current (primary busbar)	Rated operating current $I_e^{4)}$	800 A	1150 A	IP 54
			860 A	1300 A	IP 43
			1000 A ⁵⁾	1600 A ²⁾	IP 2X
		Rated surge current resistance I_{pk}	68 kA	110 kA	EN 60 439-1
Rated short-time current resistance I_{cw}	32 kA, 1 sec.	50 kA, 1 sec./50 kA, 3 sec.			
Testing under accidental arc conditions	Permissible uninfluenced short-circuit current	30 kA	50 kA	EN 61 641	
	Test voltage	690 V			
	Permissible arc duration	0.3 sec.			
Mechanical characteristics	Busbar	Material	E-Cu, bare		
		Version (cross-section)	30 x 10 mm (300 mm ²)	PLS 1600 (900 mm ²)	

1) Using outlet filter SK 3326.207 and roof plate IP 2X.

2) Using fan-and-filter unit SK 3327.107 (700 m³/h) and roof plate IP 2X.

3) Other sizes available on request.

4) Other rated currents for different protection categories on request.

5) Using fan-and-filter unit SK 3325.107 (230 m³/h) and roof plate IP 2X.

SV-TS 8 enclosures for modular outgoing chambers

Enclosures				
Mechanical characteristics	Dimensions	Enclosure width	400/600/800 mm ³⁾	
		Enclosure height	1800/2000/2200 mm ³⁾	
	Enclosure depth	600/800 mm ³⁾		
	Pitch pattern	25 mm		
	Protection rating		Max. IP 54	EN 60 529
Surface protection/ material	Design	Enclosure frame	Dipcoat-primed	EN 60 439-1
		Panels (roof plate, rear panel)	Dipcoat-primed, powder-coated in RAL 7035 on the outside	
		System attachment	Stainless steel	
		System rails and punched sections with mounting flanges	Sheet steel, zinc-plated, passivated	
Operating and ambient conditions	Ambient temperature	Short-term peak	+40°C	EN 60 439-1
		Maximum on a 24 h average	+35°C	
		Low	-5°C	
	Atmospheric conditions	Normal climatic stress		EN 60 439-1
		Relative humidity	50 % at 40°C	
		Operation up to 1000 m above sea level		

Maxi-PLS busbar system		Maxi-PLS 1600	Maxi-PLS 2000	Maxi-PLS 3200		
Electrical characteristics	Rated voltage	Rated insulation voltage U_i	1000 V		EN 60 439-1	
		Rated operating voltage U_e	690 V			
		Rated surge voltage resistance U_{imp}	8 kV			
		Overvoltage category	IV			
		Level of contamination	3			
		Rated frequency	50 Hz			
	Rated current (primary busbar)	Rated operating current $I_e^{4)}$	1400 A	1800 A	2800 A	For IP 54
			1600 A	2000 A	3000 A	For IP 2X ¹⁾
			1800 A	2500 A	4000 A	For IP 2X ²⁾
		Rated surge current resistance I_{pk}	110 kA		165 kA	EN 60 439-1
Rated short-time current resistance I_{cw}	50 kA		75 kA			
Testing under accidental arc conditions	Permissible uninfluenced short-circuit current	50 kA		70 kA	EN 61 641	
	Test voltage	690 V				
	Permissible arc duration	0.3 sec.				
Mechanical characteristics	Busbar	Material	E-Cu, bare			
		External dimensions (cross-section)	45 x 45 mm (1000 mm ²)	45 x 45 mm (1380 mm ²)	60 x 60 mm (2700 mm ²)	

RiLine60 busbar system		E-Cu 30 x 10 mm	PLS 1600		
Electrical characteristics	Rated voltage	Rated insulation voltage U_i	1000 V		EN 60 439-1
		Rated operating voltage U_e	690 V		
		Rated surge voltage resistance U_{imp}	8 kV		
		Overvoltage category	IV		
		Level of contamination	3		
		Rated frequency	50 Hz		
	Rated current (primary busbar)	Rated operating current $I_e^{4)}$	800 A	1150 A	IP 54
			860 A	1300 A	IP 43
			1000 A	1600 A ²⁾	IP 2X
		Rated surge current resistance I_{pk}	68 kA	110 kA	EN 60 439-1
Rated short-time current resistance I_{cw}	32 kA, 1 sec.	50 kA, 1 sec./50 kA, 3 sec.			
Rated current (distributor busbar)	Rated operating current $I_e^{4)}$	800 A	1600 A	IP 54	
		860 A	1600 A	IP 43	
		1000 A ⁵⁾	1600 A ²⁾	IP 2X	
	Rated surge current resistance I_{pk}	68 kA	110 kA	EN 60 439-1	
Rated short-time current resistance I_{cw}	32 kA, 1 sec.	50 kA, 1 sec./50 kA, 3 sec.			
Testing under accidental arc conditions	Permissible uninfluenced short-circuit current	30 kA	50 kA	EN 61 641	
	Test voltage	690 V			
	Permissible arc duration	0.3 sec.			
Mechanical characteristics	Busbar	Material	E-Cu, bare		
		Version (cross-section)	30 x 10 mm (300 mm ²)	PLS 1600 (900 mm ²)	

¹⁾ Using outlet filter SK 3326.207 and roof plate IP 2X.

²⁾ Using fan-and-filter unit SK 3327.107 (700 m³/h) and roof plate IP 2X.

³⁾ Other sizes available on request.

⁴⁾ Other rated currents for different protection categories on request.

⁵⁾ Using fan-and-filter unit SK 3325.107 (230 m³/h) and roof plate IP 2X.

Form 2-4 technical information

System data

SV-TS 8 enclosures

for cable chambers

Enclosures					
Mechanical characteristics	Dimensions	Enclosure width	300/400/600 mm ³⁾		
		Enclosure height	1800/2000/2200 mm ³⁾		
		Enclosure depth	600/800 mm ³⁾		
	Protection rating	Pitch pattern	25 mm		
	Design		Max. IP 54		
				1 – 4	
Surface protection/ material	Enclosure frame	Dipcoat-primed			
	Panels (roof plate, rear panel)	Dipcoat-primed, powder-coated in RAL 7035 on the outside			
	System attachment	Stainless steel			
	System rails and punched sections with mounting flanges	Sheet steel, zinc-plated, passivated			
Operating and ambient conditions	Ambient temperature	Short-term peak	+40°C		
		Maximum on a 24 h average	+35°C		
		Low	-5°C		
	Atmospheric conditions	Normal climatic stress			
		Relative humidity	50 % at 40°C		
		Operation up to 1000 m above sea level			

Maxi-PLS busbar system		Maxi-PLS 1600	Maxi-PLS 2000	Maxi-PLS 3200		
Electrical characteristics	Rated voltage	Rated insulation voltage U_i	1000 V			EN 60 439-1
		Rated operating voltage U_e	690 V			
		Rated surge voltage resistance U_{imp}	8 kV			
		Overtoltage category	IV			
		Level of contamination	3			
		Rated frequency	50 Hz			
	Rated current (primary busbar)	Rated operating current $I_e^{4)}$	1400 A	1800 A	2800 A	For IP 54
			1600 A	2000 A	3000 A	For IP 2X ¹⁾
			1800 A	2500 A	4000 A	For IP 2X ²⁾
		Rated surge current resistance I_{pk}	110 kA		165 kA	EN 60 439-1
Rated short-time current resistance I_{cw}	50 kA		75 kA			
Testing under accidental arc conditions	Permissible uninfluenced short-circuit current	50 kA		70 kA	EN 61 641	
	Test voltage	690 V				
	Permissible arc duration	0.3 sec.				
Mechanical characteristics	Busbar	Material	E-Cu, bare			
		External dimensions (cross-section)	45 x 45 mm (1000 mm ²)	45 x 45 mm (1380 mm ²)	60 x 60 mm (2700 mm ²)	

RiLine60 busbar system		E-Cu 30 x 10 mm	PLS 1600		
Electrical characteristics	Rated voltage	Rated insulation voltage U_i	1000 V		EN 60 439-1
		Rated operating voltage U_e	690 V		
		Rated surge voltage resistance U_{imp}	8 kV		
		Overtoltage category	IV		
		Level of contamination	3		
		Rated frequency	50 Hz		
	Rated current (primary busbar)	Rated operating current $I_e^{4)}$	800 A	1150 A	IP 54
			860 A	1300 A	IP 43
			1000 A ⁵⁾	1600 A ²⁾	IP 2X
		Rated surge current resistance I_{pk}	68 kA	110 kA	EN 60 439-1
Rated short-time current resistance I_{cw}	32 kA, 1 sec.	50 kA, 1 sec./50 kA, 3 sec.			
Testing under accidental arc conditions	Permissible uninfluenced short-circuit current	30 kA	50 kA	EN 61 641	
	Test voltage	690 V			
	Permissible arc duration	0.3 sec.			
Mechanical characteristics	Busbar	Material	E-Cu, bare		
		Version (cross-section)	30 x 10 mm (300 mm ²)	PLS 1600 (900 mm ²)	

¹⁾ Using outlet filter SK 3326.207 and roof plate IP 2X.

²⁾ Using fan-and-filter unit SK 3327.107 (700 m³/h) and roof plate IP 2X.

³⁾ Other sizes available on request.

⁴⁾ Other rated currents for different protection categories on request.

⁵⁾ Using fan-and-filter unit SK 3325.107 (230 m³/h) and roof plate IP 2X.

Rated currents and short-circuit currents

Rated voltage $U_N = 400\text{ V}$	400 V		
Short-circuit voltage U_k		4 % ¹⁾	6 % ²⁾
Power consumption S_{NT} [kVA]	Rated current I_N [A]	Short-circuit current $I_{k''}$ ³⁾ [kA]	
50	72	1.89	1.20
100	144	3.61	2.41
160	230	5.77	3.85
200	288	7.22	4.81
250	360	9.02	6.01
315	455	11.36	7.58
400	589	14.43	9.62
500	722	18.04	12.03
630	910	22.73	15.15
800	1156	28.86	19.24
1000	1444	36.08	24.05
1250	1805	45.09	30.06
1600	2312	57.72	38.48
2000	2882	72.15	48.10

¹⁾ $U_k = 4\%$ standardised to DIN 42 503 for $S_{NT} = 50 \dots 630\text{ kVA}$

²⁾ $U_k = 6\%$ standardised to DIN 42 511 for $S_{NT} = 100 \dots 1600\text{ kVA}$

³⁾ $I_{k''}$ = Initial symmetrical short-circuit current of transformer when connecting to a mains supply with unlimited short-circuit lead

Ri4Power



Form 1

Low-voltage switchgear in an open design



The modular solution comprising the TS 8 Top enclosure system and the standardised Maxi-PLS busbars. See Cat. 32, page 413.

Applications:

- Main current distribution systems
- Current rectification applications
- Wind power
- Industry distribution systems
- Mechanical engineering

Form 2-4

Low-voltage switchgear with form separation



Modular form separation of the TS 8 Top enclosure system in conjunction with busbar systems up to 4000 A as a modular solution.

Applications:

- Process industry
- Water supply/disposal
- Building distribution
- Chemical industry
- Mechanical engineering

ISV

Distribution enclosure



Everything from a single source: ISV-TS 8 enclosure system, ISV-AE wall-mounted distributors, ISV modules and SV components. See Cat. 32, page 457.

Applications:

- Building distribution systems
- Industry distribution systems
- Subdistribution systems

Technical specifications:

Rated voltage:
up to 690 V AC

Rated currents:
up to 4000 A

Rated transient current resistance:
up to 70/124 kA

Protection category:
up to IP 54

Rated voltage:
up to 690 V AC

Rated currents:
up to 4000 A

Rated transient current resistance:
up to 75 kA

Protection category:
up to IP 54

Rated voltage:
up to 690 V AC

Rated currents:
up to 630 A,
up to 1600 A

Rated transient current resistance:
up to 50 kA

Protection category:
up to IP 54

Rittal Ri4Power – structured system solutions for the reliable, fast assembly of low-voltage switchgear systems

for machines, plant, and buildings. Rittal Ri4Power is the new term for high-current, low-voltage switchgear and distribution enclosures under one roof – in accordance with the internationally valid standard IEC 60 439-1.

Be amazed at just how easily and precisely your solution can be created. There are two decisive features: Combination scope and compatibility. These two terms encompass all the major advantages. The combination scope makes Ri4Power the optimum solution for your application.

And the compatibility of the components ensures improved economics.

Software

Planning, configuration, selection

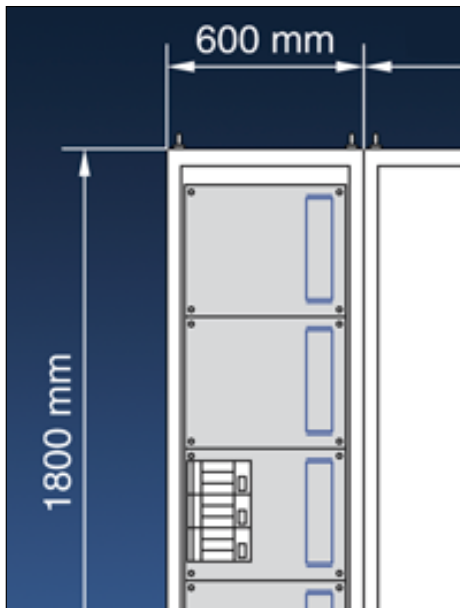

Innovative software – the fast, perfect route to your individual Ri4Power system solution.

Rittal Power Engineering

- For planners: Tendering text and plan drawings at the press of a button.
- For quote preparation: the exact costing for each part in just a few steps.
- For plant manufacturers: field-related bills of materials and drawings at the press of a button.
See Cat. 32, page 1153.

Ri4Power
Type-tested to IEC 60 439-1
Accidental arc testing to IEC 61 641

Components

Modular individuality:
Enclosure system and system accessories



TS 8, the Top enclosure system, is the system platform for all Ri4Power applications. Each enclosure is a specialist for even the most exceptional tasks. By combining Ri4Power and busbar components with general system accessories, you can create infinite power distribution possibilities.

Uncompromising safety:
RiLine60, Maxi-PLS and Flat-PLS busbar systems



Type-tested system technology for all low-voltage applications in control and power distribution engineering.

The busbar systems offer a host of useful features to make installation, assembly and operation easy and uncomplicated. For the plant operator, the Rittal Ri4Power guarantees uncompromisingly high safety standards in power distribution.

List of model numbers

3031.000 to 9640.380

Model No.	Page	Model No.	Page	Model No.	Page	Model No.	Page
3031.000	89	7825.805	34	9340.000	56	9342.510	62
3032.000	89	8106.235	33	9340.004	64	9342.514	70
3079.000	95	8108.235	33	9340.010	56	9342.540	62
3079.010	95	8126.235	33	9340.030	88	9342.550	62
3085.000	88	8128.235	33	9340.035	88	9342.560	96
3092.000	88	8186.235	33	9340.040	88	9342.570	97
3439.010	61	8601.000	34	9340.070	56	9342.600	63
3504.000	90	8601.010	34	9340.074	64	9342.604	70
3505.000	90	8601.015	34	9340.090	96	9342.610	63
3509.000	58	8601.025	34	9340.100	57	9342.614	70
3509.200	58	8601.026	34	9340.110	57	9342.640	96
3514.000	90	8601.030	34	9340.120	57	9342.660	97
3515.000	90	8601.040	34	9340.130	57	9342.670	97
3516.000	58	8601.050	34	9340.134	65	9342.680	97
3516.200	58	8601.060	34	9340.140	57	9342.690	97
3524.000	58	8601.065	34	9340.170	57	9342.700	63
3524.200	58	8601.080	34	9340.200	57, 59	9342.710	63
3525.000	58	8601.085	34	9340.210	57, 59	9342.720	96
3525.010	58	8601.086	34	9340.214	65, 67	9342.770	97
3525.200	58	8601.092	34	9340.220	57, 59	9342.780	97
3525.210	58	8601.095	34	9340.224	65, 67	9342.790	97
3526.000	58	8601.200	34	9341.000	58	9350.075	90
3526.200	58	8601.300	34	9341.070	58	9640.000	74
3527.000	58	8601.400	34	9341.100	59	9640.010	74
3527.200	58	8601.500	34	9341.110	59	9640.020	75
3528.000	58	8601.600	34	9341.120	59	9640.050	74
3528.010	58	8601.602	34	9341.130	59	9640.060	74
3528.200	58	8601.605	34	9341.140	59	9640.080	74
3528.210	58	8601.800	34	9341.170	59	9640.088	74
3529.000	58	8601.802	34	9342.000	58	9640.098	74
3529.200	58	8601.805	34	9342.004	66	9640.160	74
3565.000	95	8601.850	34	9342.014	66	9640.170	75
3565.010	95	8601.905	34	9342.070	58	9640.180	75
3566.000	95	8601.915	34	9342.074	66	9640.190	74
3567.000	95	8601.920	34	9342.100	59	9640.201	74
3568.000	95	8602.000	34	9342.110	59	9640.206	74
3569.000	95	8602.015	34	9342.120	59	9640.211	74
3570.000	95	8602.025	34	9342.130	59	9640.216	74
3571.000	95	8602.030	34	9342.134	67	9640.221	74
3572.000	95	8602.040	34	9342.140	59	9640.226	74
3573.000	95	8602.050	34	9342.170	59	9640.231	74
3574.000	95	8602.060	34	9342.200	60	9640.236	74
3575.000	95	8602.065	34	9342.210	60	9640.241	74
3576.000	95	8602.080	34	9342.220	60	9640.246	74
3577.000	95	8602.085	34	9342.224	68	9640.251	74
3578.000	95	8602.095	34	9342.230	60	9640.256	74
3579.000	95	8602.100	34	9342.234	68	9640.261	74
3580.000	88	8602.200	34	9342.240	60	9640.266	74
3580.100	88	8602.400	34	9342.244	68	9640.271	74
3581.000	88	8602.500	34	9342.250	60	9640.276	74
3581.100	88	8602.600	34	9342.254	68	9640.281	74
3582.000	88	8602.605	34	9342.260	60	9640.286	74
3583.000	88	8602.800	34	9342.264	68	9640.291	74
3584.000	88	8602.805	34	9342.270	60	9640.296	74
3585.000	88	8602.850	34	9342.274	68	9640.301	74
3586.000	88	8602.905	34	9342.280	60	9640.306	74
3587.000	88	8602.915	34	9342.290	60	9640.311	74
3588.000	88	8602.920	34	9342.300	60	9640.316	74
3589.000	88	8700.000	35	9342.310	61, 69	9640.325	75
3590.000	88	8800.430	35	9342.314	69	9640.330	75
3590.010	88	8800.490	35	9342.320	61, 69	9640.340	75
7825.601	34	9320.020	90	9342.324	69	9640.350	75
7825.603	34	9320.030	90	9342.400	62	9640.360	74
7825.605	34	9320.060	90	9342.410	62	9640.365	74
7825.801	34	9320.070	90	9342.500	62	9640.370	75
7825.803	34	9320.120	96	9342.504	70	9640.380	75

List of model numbers

9640.433 to 9671.736

Model No.	Page	Model No.	Page	Model No.	Page	Model No.	Page
9640.433	75	9650.470	77	9661.240	89	9671.038	35
9640.434	75	9650.480	77	9661.300	89	9671.043	35
9640.443	75	9650.487	77	9661.305	89	9671.044	35
9640.444	75	9650.700	94	9661.320	89	9671.046	35
9640.453	75	9650.900	77	9661.325	89	9671.048	35
9640.454	75	9650.910	77	9661.330	89	9671.120	37
9640.473	75	9650.920	77	9661.335	89	9671.126	37
9640.474	75	9650.930	77	9661.340	89	9671.128	37
9640.483	75	9650.940	77	9661.345	89	9671.130	37
9640.484	75	9650.960	77	9661.350	89	9671.132	37
9640.700	94	9650.980	77	9661.355	89	9671.134	37
9640.705	94	9650.990	77	9661.360	89	9671.135	37
9640.900	75	9659.000	76	9661.365	89	9671.138	37
9640.910	75	9659.010	76	9661.380	89	9671.140	37
9640.920	75	9659.020	77	9661.385	89	9671.141	37
9640.930	75	9659.030	77	9665.750	39	9671.142	37
9640.940	75	9659.060	76	9665.760	39	9671.143	37
9640.960	75	9659.078	76	9665.770	39	9671.144	37
9640.970	75	9659.170	77	9665.780	39	9671.146	37
9640.980	75	9659.180	77	9665.785	39	9671.147	37
9649.000	74	9659.190	76	9665.903	38	9671.148	37
9649.010	74	9659.360	76	9670.206	32	9671.150	37
9649.020	75	9659.403	77	9670.208	32	9671.156	37
9649.060	74	9659.404	77	9670.226	32	9671.158	37
9649.076	74	9659.413	77	9670.228	32	9671.160	37
9649.078	74	9659.414	77	9670.316	30	9671.161	37
9649.170	75	9659.423	77	9670.318	30	9671.162	37
9649.190	74	9659.424	77	9670.336	31	9671.163	37
9649.360	74	9659.473	77	9670.338	31	9671.164	37
9650.000	76	9659.474	77	9670.396	29	9671.166	37
9650.010	76	9659.483	77	9670.406	27	9671.167	37
9650.020	77	9659.484	77	9670.408	27	9671.168	37
9650.030	77	9659.493	77	9670.416	30	9671.170	37
9650.050	76	9659.494	77	9670.418	30	9671.176	37
9650.060	76	9659.525	38	9670.426	28	9671.178	37
9650.076	76	9659.535	38	9670.428	28	9671.180	37
9650.080	76	9660.200	51	9670.436	31	9671.181	37
9650.098	76	9660.235	38	9670.438	31	9671.182	37
9650.100	76	9660.245	38	9670.486	26	9671.183	37
9650.140	76	9660.313	94	9670.496	29	9671.184	37
9650.160	76	9660.314	94	9670.606	27	9671.186	37
9650.170	77	9660.318	94	9670.608	27	9671.187	37
9650.180	77	9660.319	94	9670.616	30	9671.188	37
9650.190	76	9660.363	94	9670.618	30	9671.190	37
9650.201	76	9660.368	94	9670.626	28	9671.196	37
9650.211	76	9660.369	94	9670.628	28	9671.198	37
9650.221	76	9660.935	38	9670.636	31	9671.446	38
9650.231	76	9660.945	38	9670.638	31	9671.448	38
9650.241	76	9660.970	46	9670.686	26	9671.468	38
9650.251	76	9661.000	89	9670.696	29	9671.488	38
9650.261	76	9661.020	89	9670.806	27	9671.536	38
9650.271	76	9661.030	89	9670.808	27	9671.538	38
9650.281	76	9661.040	89	9670.826	28	9671.546	38
9650.291	76	9661.050	89	9670.828	28	9671.548	38
9650.301	76	9661.060	89	9670.886	26	9671.568	38
9650.311	76	9661.080	89	9671.003	36	9671.586	38
9650.325	77	9661.100	89	9671.004	36	9671.588	38
9650.330	77	9661.120	89	9671.006	36	9671.636	38
9650.340	77	9661.130	89	9671.008	36	9671.638	38
9650.350	77	9661.140	89	9671.013	35	9671.646	38
9650.360	76	9661.150	89	9671.014	35	9671.648	38
9650.370	77	9661.160	89	9671.016	35	9671.666	38
9650.380	77	9661.180	89	9671.018	35	9671.668	38
9650.400	77	9661.200	89	9671.033	35	9671.686	38
9650.410	77	9661.230	89	9671.034	35	9671.688	38
9650.420	77	9661.235	89	9671.036	35	9671.736	38

List of model numbers

9671.738 to 9675.357

Model No.	Page	Model No.	Page	Model No.	Page	Model No.	Page
9671.738	38	9673.086	43	9673.640	48	9674.102	80
9671.746	38	9673.089	43	9673.641	48	9674.104	80
9671.748	38	9673.152	43	9673.642	48	9674.122	80
9671.766	38	9673.155	43	9673.643	48	9674.124	80
9671.768	38	9673.162	43	9673.644	48	9674.162	80
9671.786	38	9673.165	43	9673.646	48	9674.164	80
9671.788	38	9673.166	43	9673.647	48	9674.172	80
9671.906	33	9673.182	43	9673.648	48	9674.174	80
9671.908	33	9673.185	43	9673.651	48	9674.182	80
9671.926	33	9673.186	43	9673.652	48	9674.184	80
9671.928	33	9673.192	43	9673.653	48	9674.192	80
9671.986	33	9673.195	43	9673.654	48	9674.194	80
9671.996	33	9673.405	45	9673.657	48	9674.196	94
9671.998	33	9673.406	45	9673.660	48	9674.198	94
9672.000	38	9673.408	45	9673.661	48	9674.761	49
9672.002	38	9673.416	45	9673.662	48	9674.762	49
9672.003	38	9673.418	45	9673.663	48	9674.763	49
9672.004	38	9673.426	45	9673.664	48	9674.764	49
9672.006	38	9673.428	45	9673.666	48	9674.781	49
9672.008	38	9673.430	47	9673.667	48	9674.782	49
9672.010	36	9673.434	47	9673.668	48	9674.783	49
9672.012	36	9673.436	47	9673.671	48	9674.784	49
9672.013	36	9673.437	47	9673.672	48	9675.130	91
9672.014	36	9673.438	47	9673.673	48	9675.133	91
9672.016	36	9673.439	47	9673.674	48	9675.136	91
9672.018	36	9673.440	46	9673.677	48	9675.140	91
9672.020	36	9673.441	46	9673.680	48	9675.143	91
9672.022	36	9673.444	46	9673.681	48	9675.146	91
9672.023	36	9673.445	46	9673.682	48	9675.153	91
9672.024	36	9673.448	46	9673.683	48	9675.156	91
9672.026	36	9673.449	46	9673.684	48	9675.163	91
9672.028	36	9673.450	47	9673.686	48	9675.166	91
9672.030	36	9673.454	47	9673.687	48	9675.210	92
9672.032	36	9673.456	47	9673.688	48	9675.212	92
9672.033	36	9673.457	47	9673.691	48	9675.218	92
9672.034	36	9673.458	47	9673.692	48	9675.220	92
9672.036	36	9673.459	47	9673.693	48	9675.222	92
9672.038	36	9673.460	46	9673.694	48	9675.230	92
9672.040	36	9673.461	46	9673.697	48	9675.232	92
9672.042	36	9673.464	46	9673.901	50	9675.238	92
9672.043	36	9673.465	46	9673.902	50	9675.240	92
9672.044	36	9673.468	46	9673.903	50	9675.242	92
9672.046	36	9673.469	46	9673.915	49	9675.303	91
9672.048	36	9673.470	47	9673.920	49	9675.304	91
9672.050	36	9673.471	47	9673.930	49	9675.306	91
9672.052	36	9673.474	47	9673.931	49	9675.307	91
9672.053	36	9673.475	47	9673.940	49	9675.313	91
9672.054	36	9673.476	47	9673.941	49	9675.314	91
9672.056	36	9673.477	47	9673.942	49	9675.316	91
9672.058	36	9673.478	47	9673.943	49	9675.317	91
9673.004	46	9673.479	47	9673.950	49	9675.323	91
9673.006	46	9673.480	46	9673.951	49	9675.324	91
9673.008	46	9673.481	46	9673.952	49	9675.326	91
9673.051	43	9673.484	46	9673.953	49	9675.327	91
9673.052	43	9673.485	46	9673.960	49	9675.333	91
9673.055	43	9673.488	46	9673.961	49	9675.334	91
9673.060	44	9673.489	46	9673.972	49	9675.336	91
9673.061	43	9673.504	47	9673.973	49	9675.337	91
9673.062	43	9673.506	47	9673.980	49	9675.343	91
9673.065	43	9673.508	47	9673.981	49	9675.344	91
9673.066	43	9673.530	44	9673.982	49	9675.346	91
9673.069	43	9673.532	44	9673.983	49	9675.347	91
9673.080	44	9673.540	44	9674.003	92	9675.353	91
9673.081	43	9673.542	44	9674.004	92	9675.354	91
9673.082	43	9673.560	44	9674.006	92	9675.356	91
9673.085	43	9673.562	44	9674.008	92	9675.357	91

List of model numbers

9675.363 to 9676.987

Model No.	Page	Model No.	Page	Model No.	Page
9675.363	91	9676.243	86	9676.548	85
9675.364	91	9676.244	86	9676.620	85
9675.366	91	9676.245	86	9676.626	85
9675.367	91	9676.246	86	9676.628	85
9675.373	91	9676.253	86	9676.640	85
9675.374	91	9676.254	86	9676.646	85
9675.376	91	9676.255	86	9676.648	85
9675.377	91	9676.256	86	9676.701	84
9676.002	80	9676.257	86	9676.703	84
9676.004	80	9676.258	86	9676.705	84
9676.006	82	9676.261	86	9676.707	84
9676.007	82	9676.262	86	9676.711	84
9676.008	82	9676.263	86	9676.713	84
9676.011	83	9676.264	86	9676.715	84
9676.012	83	9676.265	86	9676.717	84
9676.013	83	9676.266	86	9676.721	85
9676.014	83	9676.273	86	9676.723	85
9676.015	83	9676.274	86	9676.731	84
9676.016	83	9676.275	86	9676.733	84
9676.020	81	9676.276	86	9676.910	78
9676.021	81	9676.277	86	9676.912	78
9676.022	81	9676.278	86	9676.961	87, 93
9676.023	81	9676.301	86	9676.962	87, 93
9676.024	81	9676.303	86	9676.963	87, 93
9676.025	81	9676.305	86	9676.971	93
9676.041	83	9676.313	86	9676.972	93
9676.042	83	9676.315	86	9676.973	93
9676.043	83	9676.317	86	9676.976	93
9676.046	83	9676.321	86	9676.977	93
9676.047	83	9676.322	86	9676.981	93
9676.048	83	9676.323	86	9676.982	93
9676.052	83	9676.324	86	9676.983	93
9676.053	83	9676.325	86	9676.986	93
9676.054	83	9676.326	86	9676.987	93
9676.056	83	9676.333	86		
9676.058	83	9676.334	86		
9676.059	83	9676.335	86		
9676.194	51	9676.336	86		
9676.196	51	9676.337	86		
9676.198	51	9676.338	86		
9676.201	86	9676.341	86		
9676.202	86	9676.343	86		
9676.203	86	9676.345	86		
9676.204	86	9676.353	86		
9676.205	86	9676.355	86		
9676.206	86	9676.357	86		
9676.213	86	9676.361	86		
9676.214	86	9676.362	86		
9676.215	86	9676.363	86		
9676.216	86	9676.364	86		
9676.217	86	9676.365	86		
9676.218	86	9676.366	86		
9676.221	86	9676.373	86		
9676.222	86	9676.374	86		
9676.223	86	9676.375	86		
9676.224	86	9676.376	86		
9676.225	86	9676.377	86		
9676.226	86	9676.378	86		
9676.233	86	9676.503	93		
9676.234	86	9676.504	93		
9676.235	86	9676.505	93		
9676.236	86	9676.520	85		
9676.237	86	9676.526	85		
9676.238	86	9676.528	85		
9676.241	86	9676.540	85		
9676.242	86	9676.546	85		

Index

A

Accessories	88, 97
Additional attachment	
– for busbar support 1-pole	88
Angular baying bracket	
– for TS	35

B

Base isolators	89
Base tray infill	57, 59
Base trays	57, 59, 65, 67
Base/plinth components	
– Front and rear	34
Base/plinth trim panels	
– Side	34
Baying brackets	
– for TS	35
– PE/PEN	89
Baying connector	
– for TS	35
Bolts Maxi-PLS	75, 77
Busbar claw	
– for Flat-PLS	83
Busbar connection adaptor	
– 3-pole	60, 61
– 4-pole	68, 69
Busbar connectors	90
Busbar enclosures, SV-TS 8	32
Busbar stabiliser bars	
– for busbar support Flat-PLS	81
Busbar support Flat-PLS	80
– for stabiliser bar	81
Busbar support Maxi-PLS	74, 76
Busbar support RiLine60	
– 4-pole	64, 66
– PLS	58
– PLUS	66
Busbar systems	
– 1- and 2-pole	88
– 3-pole (RiLine60)	56, 63
– 4-pole (RiLine60)	64, 70
– Flat-PLS	80, 87
– Maxi-PLS	74, 79
Busbars	
– Cover section	88
– E-Cu	88, 89, 92
– Maxi-PLS	74, 76
– PE/PEN	89
– PLS	58, 66, 92

C

Cable chamber enclosures SV-TS 8	29, 31
Cable entry glands	39
Circuit-breaker	
– component adaptor	62, 63, 70
Clamps	
– Maxi-PLS	75, 77
Combination angles	
– PE/PEN	89
Compartment configuration	42
Component adaptor	
– Circuit-breaker	62, 63, 70
Component adaptor extension piece	96
Connection brackets	
– for circuit-breaker	
– component adaptors	97
– for Flat-PLS	86
– Maxi-PLS	75, 77
Connection clamps	
– Maxi-PLS	75, 77
Connection kits	
– for busbar riser	94
Connection plates	
– Flat-PLS	84
– Maxi-PLS	75, 77
Connection plates	
– for laminated copper bars	
– for Flat-PLS	85
Connection plates with bolts M10/12/16	
– for Flat-PLS	84
Connection space covers	44
Connection terminals	
– Flat-PLS	84
Connector	
– for busbars	90
– for Flat-PLS	85
– for Mini-TS profile	50
– Maxi-PLS	74, 76
Connector kits	
– for Flat-PLS	87
– for Maxi-PLS/Flat-PLS	78, 79
– for Maxi-PLS/RiLine60 bar systems	91
Connector pieces	
– for Mini-TS profile	50
Contact makers	
– for Flat-PLS	85
– Maxi-PLS	75, 77
Copper bars	
– E-Cu	88, 89
– Maxi-PLS	74, 76
– PLS special busbars	58
– PLUS	66
– RiLine60 bar systems	56
– Rittal Flexibar “S”	95
Copper castors (spacers)	93
Corner bracket E-Cu	94
Corner connector	
– for Mini-TS profile	50
Coupling set mounting kit	94
Cover plates	44
Cover sections	
– for base tray	57, 59, 65, 67
– for busbars	88
– for Flat-PLS	83
– Maxi-PLS	74, 76
Covers for busbar claws	83
Cross members for TS	36

D

Direct connection terminals	
– for Flat-PLS	84
Distributor busbars	92

E

Enclosure configuration	33, 39
Enclosures, SV-TS 8	26, 32
– Busbar enclosures	32
– Cable chamber enclosures	29, 31
– Modular enclosures	26, 28
– System data	107
End covers for busbar support	
– 3-pole	56, 58
– 4-pole	64, 66
– Flat-PLS	82
– Maxi-PLS	74, 76
– PLS	58
– PLUS	66
End support	
– Maxi-PLS	74, 76
Expansion connector PLS	90

F

Filler pieces	
– for busbar support Flat-PLS	82
Flat-PLS bar systems	80, 87
Frame adaptor piece	
– for Mini-TS profile	50
Front trim panels	
– for TS	35, 36
Functional space divider	
– for TS	46, 47
– Mounting bracket	45
Functional space side panel modules	
– for cable connection space	43
– for TS	43

G

Gland plates	43
– for cable entry	39

I

Insert strip	96
Isolator chassis	
– Maxi-PLS	75, 77

L

Laminated copper bars	95
Locks (twist locks)	37
Longitudinal connectors	
– for Flat-PLS	85
– Maxi-PLS	74, 76

M

Maxi-PLS	
– Bar systems	74, 79
Mini-TS extrusions	49
Mini-TS profiles	49
Modular enclosures SV-TS 8	26, 28
Mounting bracket	
– for functional space divider	45
– for functional space divider and power circuit-breaker support bar	45
Mounting kit	
– Coupling set	94
– for power circuit-breaker installation	46
Mounting plates	
– for Ri4Power Form 2-4	48

N

Nuts	
– for PS punched rail	39

P

Partial doors	
– for TS	37
Partial mounting plates	
– for TS	48
PE/PEN combination angle	89
PLS	
– Busbar connectors	90
– Expansion connectors	90
– Special busbars	58, 66, 92
Power circuit-breaker support bar	46
PS mounting rails	39
Punched rail	
– 17 x 15.5 mm, TS	49

R

RiLine60 busbar support	
– 1- and 2-pole	88
– 3-pole	56, 58
RiLine60 busbar systems	56, 70
Roof frame bars	
– for TS	38
Roof plates	
– for TS	38

S

Screw connections M12	87, 93
Short-circuit resistance diagrams	
– Busbar supports	98, 99
– Laminated copper bars	101
Side panel modules	
– for cable connection space	43
– for TS	43
Side panels	
– for TS	33
Sliding blocks	
– for circuit-breaker component adaptor	96
– Maxi-PLS	75, 77
Sliding nuts	
– Maxi-PLS	75, 77
Spacers	
– for busbar support Flat-PLS	82
– for RiLine60 busbar supports	96
Special busbars	
– Maxi-PLS	74, 76
– PLS	58, 66, 92
Stabiliser bars	
– Flat-PLS	81
Stabiliser Maxi-PLS	76
Stacking insulator	51
Support	
– for flat copper busbars	56, 64
– for Flat-PLS	80, 81
– for laminated copper bars	95
– Maxi-PLS	74, 76
Support bars	
– for power circuit-breakers	46
Support frame	
– for DIN rail-mounted devices	49
Support panel	
– for cover sections	57, 59, 65, 67
Support rails	
– for component adaptors	96
– for stacking insulators	51
Support RiLine60	
– PLS	58
SV-TS 8 enclosures	26, 32
System accessories	
– for SV-TS	33, 39
System attachments	
– for Flat-PLS	80
– for Maxi-PLS	74, 76
– for RiLine60	92
System data	107

T

T-connector kits	
– for Maxi-PLS/RiLine60 bar systems	91
T-connector piece	
– for Mini-TS profile	50
Technical information	98, 111
Terminal studs	93
– Maxi-PLS	75, 77
Threaded bolts	
– Maxi-PLS	75, 77
Trim panels	
– for cover sections	57, 59, 65, 67
– for TS	35
Twist locks	37

U

U contact makers	
– Maxi-PLS	75, 77
Universal support	
– for laminated copper bars	95
Upgrade kit	
– for front panels	35, 36
– for side panels	33

We reserve the right to further developments and technical modifications of our products. Such modifications, along with errors and printing errata, shall not constitute grounds for compensation. We refer customers to our Terms of Sale and Delivery.

All in all – solutions from Rittal



Industrial Enclosures



Power Distribution



Busbar systems RiLine60
Busbar systems 40/100/150/185 mm
Ri4Power low-voltage distribution systems



Electronic Packaging



System Climate Control



IT Solutions



Communication Systems

Rittal has one of the largest ranges of enclosures available for immediate delivery. However, Rittal also supplies integrated solutions – up to Level 4. This comprises mechanical installation, power supply, electronic components, climate control and central monitoring. For all of your requirements.

Fully assembled and functional. Wherever in the world you develop and implement solutions for yourself and your customers, we are close at hand. The global alliance between production, distribution and service guarantees closeness to the customer. Worldwide!

07/08 • E470

Rittal Limited · Braithwell Way · Hellaby Industrial Estate · Hellaby · Rotherham · S Yorks S66 8QY
Tel.: (01709) 704000 · Fax: (01709) 701217 · www.rittal.co.uk · eMail: information@rittal.co.uk



Switch to perfection **RITTAL**